

Foam Solutions

MUNICIPAL • INDUSTRIAL • MARINE • WILDLAND

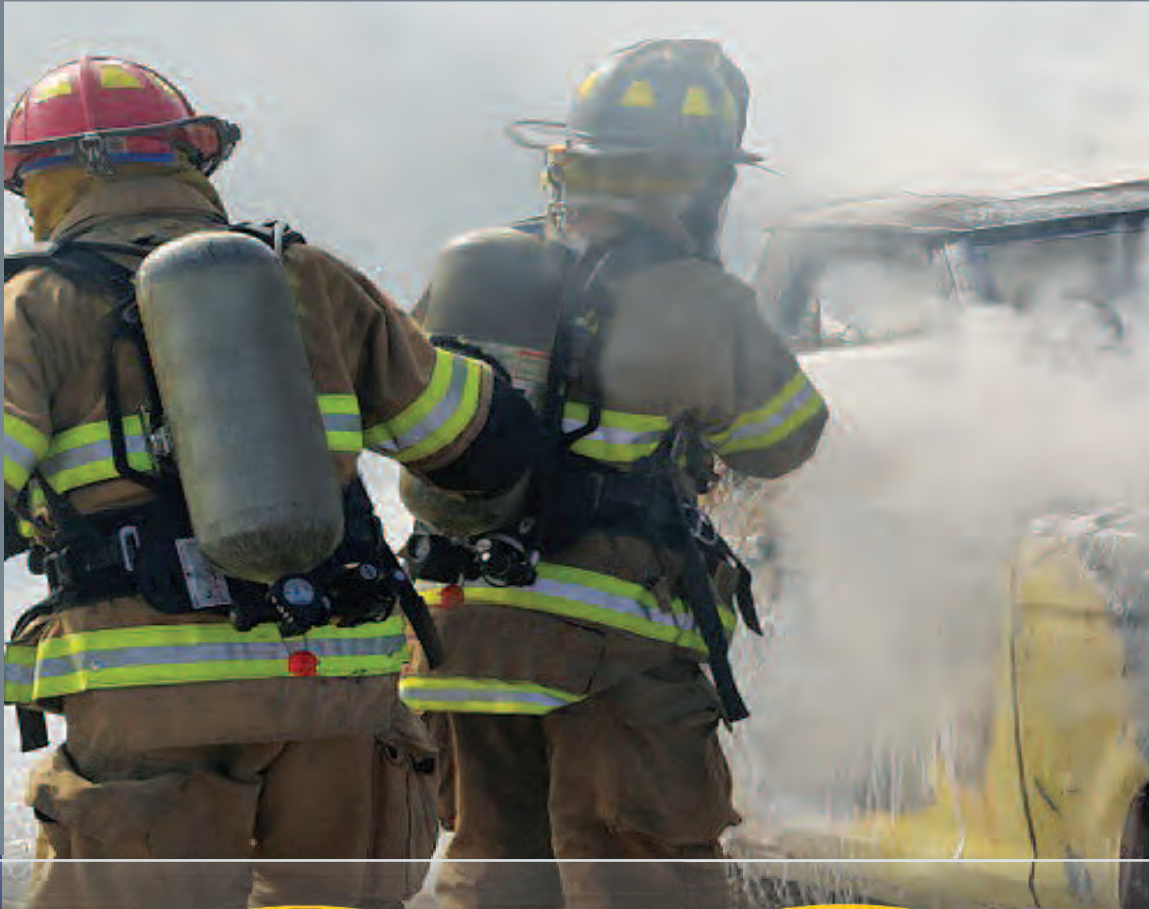

Proportioning & Refill Systems

FOAMPRO®

A Safe Fleet Brand

Choose the industry leader!

Regardless of the additive, Fire Research Corporation's FoamPro brand offers the ultimate proportioning systems for your new or retrofit apparatus. Numerous models incorporating direct injection or around-the-pump technologies are available to meet unique requirements for municipal, wildland, marine, industrial, ARFF, and CAFS applications. In addition, hundreds of options and accessories have been engineered to provide customized solutions for your specific requirements.

As the worldwide leader, FoamPro systems provide fully-automatic foam proportioning with operator-friendly controls. With concentrate capacities to 300 GPM and choices of single/multi-point direct injection or budget friendly around-the-pump systems, FoamPro has the ultimate foam management system for all of your applications.

Specify Top Performance.

Ease of use – less training

At the push of a button or turn of a dial, FoamPro is hands-down, the easiest system to use. Controls incorporate functions that are similar across the product line and intuitive to the operator; requiring less training. Automatic type systems utilize advanced microprocessor technology to manage the complete system by supplying exact amounts of foam – automatically and on demand. In the heat of a battle, it is one less thing to monitor.

Unsurpassed Features

No other proportioner delivers foam as easily and accurately as FoamPro. System designs incorporate the latest technological advancements to meet the rigorous demands of firefighting. FoamPro offers the greatest choice of models, capacities, options, and accessories to meet your specific operation and requirements - from proportioning to foam cell refill.

Foam Solution

Unmatched Accuracy – Cost Savings

FoamPro brand systems are the most accurate proportioners on the market, to within 5% or less! Unlike other proportioning technologies, FoamPro's patented automated controls assure unmatched accuracy across the full performance range, eliminating needless waste of concentrate and dollars. FoamPro automatic systems incorporate advanced microprocessor control technology that provides extremely accurate water flow measurement and precise foam solution. This pinpoint accuracy is maintained from minimum to maximum discharge, greatly reducing concentrate usage, cost, and logistical operations to re-supply.



System Reliability

Renowned for its reliability, FoamPro has proven itself since 1989 in the harshest conditions on fire grounds worldwide. We continually develop new and improved high-tech proportioning systems by incorporating ideas and suggestions from the field. To assure quality and compliance, only FoamPro requires system designs to be subjected to intense third-party testing. Stringent electronic emission control is verified according to MIL-STD 461E. Designs are then put to grueling SAE and US military specifications by independent evaluators for heavy-use, off road mobile apparatus. All FoamPro systems meet or exceed National Fire Protection Association (NFPA) standards.

Operator Interface

Automatic system designs incorporate ultra-bright LED digital displays providing the operator with real-time solution flow, injection percentage, and percentage concentrate used during operation. Other proportioning options include straight-forward controls operated by a turn of a dial or throw of a switch.

System Testing – Environmentally Green

FoamPro direct injection systems can be tested and calibrated without consuming foam concentrate or putting the environment at risk. Using the calibrate/inject valve, the system is run with the concentrate measured and directed either back to the foam cell or to a separate holding tank.

Customer Support

FoamPro systems are backed by a dedicated sales and support team averaging more than 25 years of fire industry experience. We are a great resource and happy to provide system type, sizing, or usage guidance. Please feel free to contact your local regional sales manager or our technical team with any questions for assistance.



Table of Contents

Foam Solutions	2-3
-----------------------	-----

Direct Injection Systems

Electric

1600 Series	6-9
-------------	-----

2000 Series	10-13
-------------	-------

TurboFoam	14-19
-----------	-------

Hydraulic

3012 Series	22-25
-------------	-------

AccuMax	26-31
---------	-------

Around the Pump

AutoFoam	34-35
----------	-------

Manual Foam	36-37
-------------	-------

Specialty

Mobile

Turbo Stream	40-41
--------------	-------

Refilling System

Power-Fill	42-43
------------	-------

Designing A System

1600, 2000, 3012, AccuMax	44-47
---------------------------	-------

TurboFoam	48-49
-----------	-------

AutoFoam	50
----------	----

Manual Foam	51
-------------	----

Turbo Stream, Power-Fill	51
--------------------------	----

Direct Injection

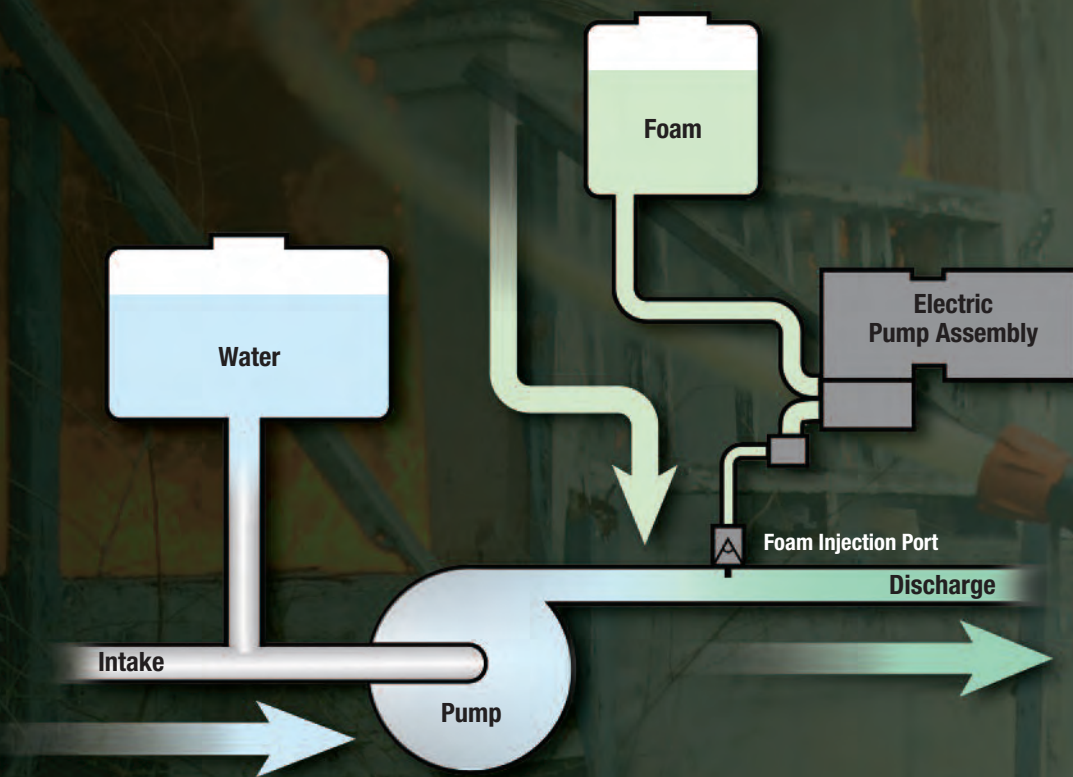

Direct injection foam proportioning systems add the foam concentrate downstream of the water pump. In this system, flushing of the water pump is not necessary.

on

Electric Systems



FOAMPRO[®]

precision foam every time.



Leading off the FoamPro line, the 1600 series proportioning systems are specifically designed for Class A foam operations. The compact system features fully automatic foam proportioning, regardless of changes in flow or pressure, and delivers unmatched accuracy over the entire flow range. Proportioning is continuous with no need to stop for foam tank refill. The panel-mounted control module provides simple operation at the flip of a switch and offers easy selection of foam percentage. Foam concentrate is delivered by a twin plunger pump coupled to a 1/3 HP motor (12 or 24 VDC). Also included is a flow sensor (choice of 1-1/2" with 1" bore, 1-1/2" or 2"), strainer, foam injection check valve, complete shielded cable set, and RFI/EMI suppression kit. The 1600 Model is engineered for greater capacity while the 1601 Model is specifically designed for extended ultra-low flow applications.

1600 Series

(Class A Foam Only)

Ideal for use on:

- Brush rigs/skid units
- Fast attack/wildland vehicles
- Municipal apparatus
- Compressed Air Foam Systems

System features and benefits:

- 3' Lift Capability
- Fully automatic-on demand
- Discharge side injection
- No in-line restrictions, greater flow
- Unmatched accuracy over the widest range of flow
- Smoothest proportioning available at ultra-low flow
- Leading the industry in proven reliability
- For use with all Class A concentrates
- Delivers 0.1 to 1.7 gpm (.38 to 6.4 L/min) of concentrate
- Injection pressure to 400 psi (27.6 BAR)
- Installs easily in new or existing apparatus

Control module features:

- Improved control head design
- Injection percentage from 0.1% to 1.0%
- On/Off control
- Foam percentage selector
- Low concentrate warning indicator
- No concentrate warning indicator
- Simulated flow - auto disengage

Options:

- Remote Start/Stop for in-cab control
- Check valves
- Flow sensor/check valve manifold
- Solid State Contactor
- Low-Level Tank Sensor
- Remote simulated flow



Optional manifold & check valve pictured.

Series

1600

1600 Series

Foam Pump:	Twin Plunger Pump
Foam Output:	1.0 gpm @ 200 psi - (3.8 L/min @ 13.8 BAR) 1601 1.7 gpm @ 200 psi - (6.4 L/min @ 13.8 BAR) 1600
Lift Capability:	3 ft 1600/1601
Pump Motor:	1/3 hp (.25 Kw) 12 and 24 volt DC
Maximum Operating Pressure:	400 psi (27.6 BAR)
Maximum Operating Temperature:	160°F (71°C)
Maximum Amp Draw:	32 amps (1601) @ 12 volt DC 32 amps (1600) @ 12 volt DC 16 amps (1601) @ 24 volt DC 16 amps (1600) @ 24 volt DC

System Capacity

Foam Concentration	1601 Maximum Water Flow GPM (L/min)	1600 Maximum Water Flow GPM (L/min)
0.2%	500 (1,893)	850 (3,218)
0.5%	200 (757)	340 (1,287)
1.0%	100 (379)	170 (644)

1600 Series Attack Capability

Class A Foam Concentration	1601 Maximum Coverage per Critical Application Rate (Iowa Formula) cu.ft (cu.m)	1600 Maximum Coverage per Critical Application Rate (Iowa Formula) cu.ft (cu.m)
0.2%	50,000 (1,415)	85,000 (2,406)
0.5%	20,000 (566)	34,000 (962)
1.0%	10,000 (283)	17,000 (481)

Series 1600

Performance for 1600 Series

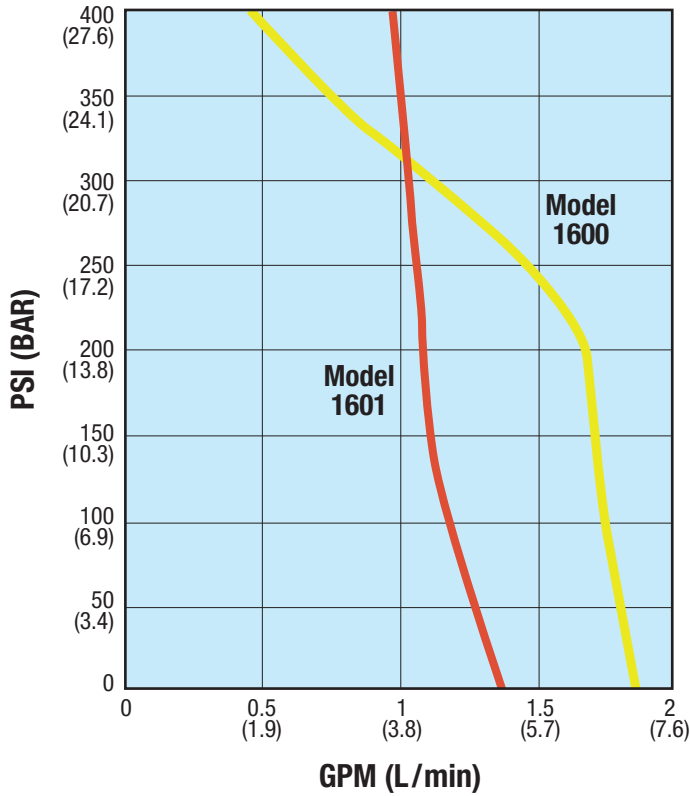

System Diagrams

1600 Series

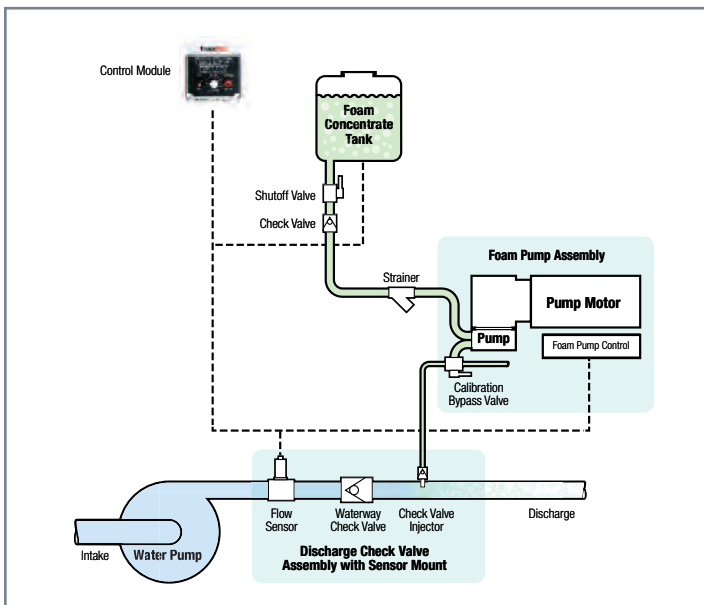

1600 Series with Single Tank Flush

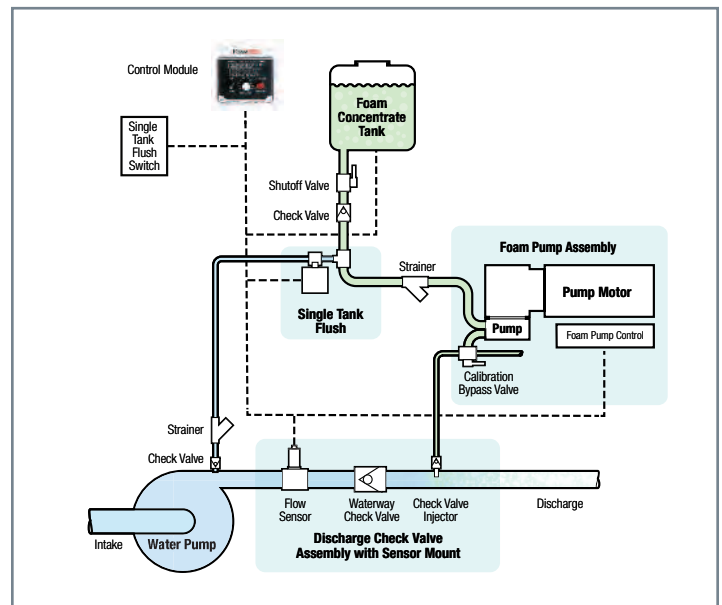



Designed for Class A and Class B foam applications, the 2000 series of proportioners delivers greater flow capabilities than the 1600 series. In addition, the panel-mounted digital control module offers easy to use, push button control. Real time flow and proportioning performance information is displayed by ultra-bright LED readouts. The system features fully automatic foam proportioning, regardless of changes in flow or pressure, and delivers unmatched accuracy over the entire flow range. Proportioning is continuous with no need to stop for foam tank refill. Three models are available, differing in concentrate capacity: the 2001 at 2.6 gpm, the 2002 at 5.0 gpm, and the 2024 (24 VDC only) at 6.3 gpm. Foam concentrate is delivered by a triplex plunger pump and motor (12 or 24 VDC) assembly. The optional advanced feature controller offers “auto-on” programming.

2000 Series

(Class A and/or B Foam)

Ideal for use on:

- Municipal pumpers
- Fast attack/wildland vehicles
- Marine and shipboard system
- Compressed Air Foam Systems

System features and benefits:

- Fully automatic-on demand
- Discharge side injection
- No in-line restrictions, greater flow
- Unmatched accuracy over the widest range of flow
- Smoothest proportioning available at ultra-low flow
- Leading the industry in proven reliability
- Proportions continuously, with no stopping to refill
- Delivers 0.01 to 6.3 gpm (0.04 - 24 L/min)
- Injection pressure to 400 psi (27.6 BAR)
- Achieves full pump capacity with all known Class A, Class B, AFFF, and most Class B AR-AFFF
- Installs easily in new or existing apparatus

Control module features:

- Ultra-bright LED digital readout
- Injection percentage from 0.1% to 10.0%
- Display following information:
 - Low concentrate/ No concentrate warning
 - Water flow rate
 - Total water used
 - Injection percentage
 - Total concentrate used
- Dual-tank capability and calibration
- Displays separate totals for each tank
- Calibrate for each concentrate

Options:

- Concentrate Management Systems
- Advanced Feature Controller - Auto On
- MultiFlo
- Remote Start/Stop for pump and roll applications
- Dual-Injection Selector
- Solid State Contactor
- Flow sensors, check valves, manifolds
- Low-Level Sensors



Low-level sensor, flow sensor & check valve pictured.

Series

2000

2000 Series

Foam Pump:	Triplex Plunger Pump
Foam Output:	2.6 gpm @ 150 psi - (9.84 L/min @ 10.3 BAR) 2001 5.0 gpm @ 125 psi - (18.9 L/min @ 10.3 BAR) 2002 6.3 gpm @ 218 psi - (24 L/min @ 15 BAR) 2024 (24 VDC only)
Pump Motor:	1/2 hp (.40 Kw) 12 and 24 volt DC - 2001 3/4 hp (.56 Kw) 12 and 24 volt DC - 2002 1-1/2 hp (1.12 Kw) 24 volt DC Only - 2024
Maximum Operating Pressure:	400 psi (27.6 BAR) STD 600 psi (41.4 BAR) Optional
Maximum Operating Temperature:	160°F (71°C)
Maximum Amp Draw:	41 amps @ 12 volt DC - 2001 60 amps @ 12 volt DC - 2002 22 amps @ 24 volt DC - 2001 30 amps @ 24 volt DC - 2002 60 amps @ 24 volt DC - 2024 (24 VDC Only)

System Capacity

Foam Concentration	2001 Maximum Water Flow GPM (L/min)	2002 Maximum Water Flow GPM (L/min)	2024 Maximum Water Flow GPM (L/min)
0.2%	1,300 (4,921)	2,500 (9,464)	3,170 (12,000)
0.5%	520 (1,968)	1,000 (3,785)	1,268 (4,800)
1.0%	260 (984)	500 (1,893)	634 (2,400)
3.0%	85 (322)	166 (628)	211 (800)

2000 Series Attack Capability

Class A Foam Concentration	2001 Maximum Coverage per Critical Application Rate cu.ft. (cu.m)	2002 Maximum Coverage per Critical Application Rate cu.ft. (cu.m)	2024 Maximum Coverage per Critical Application Rate cu.ft. (cu.m)
0.2%	130,000 (3,681)	250,000 (7,079)	317,000 (8,976)
0.5%	52,000 (1,472)	100,000 (2,831)	126,800 (3,590)
1.0%	26,000 (736)	50,000 (1,415)	63,400 (1,795)
Class B Foam Concentration	Hydrocarbon @ 0.10 gpm/sq.ft. (0.37854 LPM/sq.m) sq.ft (sq.m)		
1.0%	2,600 (241)	5,000 (464)	6,340 (589)
3.0%	850 sq. (78)	1,660 (154)	2,110 (196)
	Polar Solvent @ 0.20 gpm/sq.ft. (0.757 LPM/sq.m)		
3.0%	425 (39)	830 (77)	1,055 (98)

Series 2000

Performance for 2000 Series

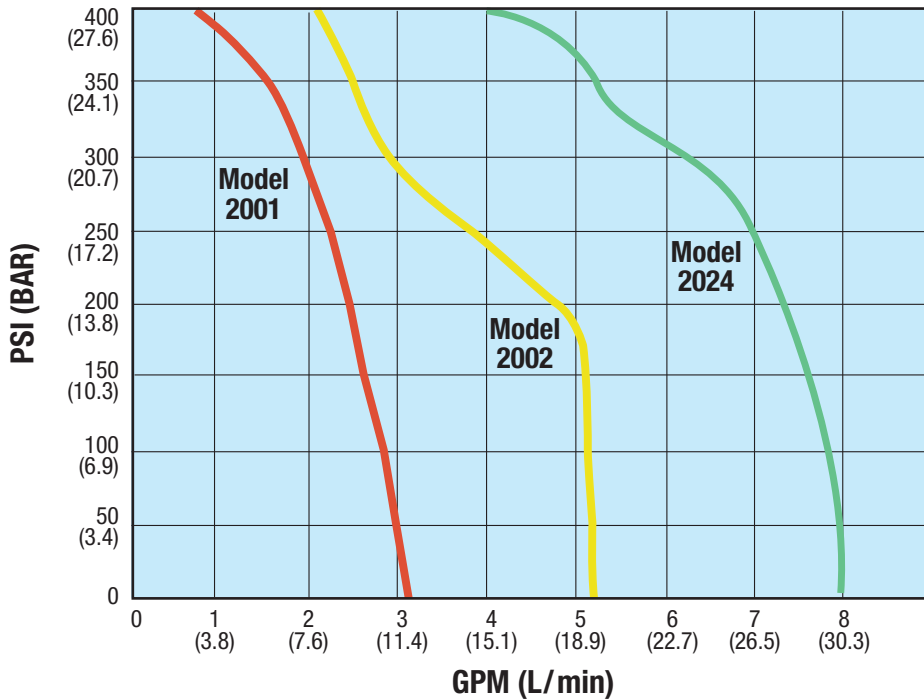

System Diagrams

2000 Series with **Manual Concentrate Mgmt System**

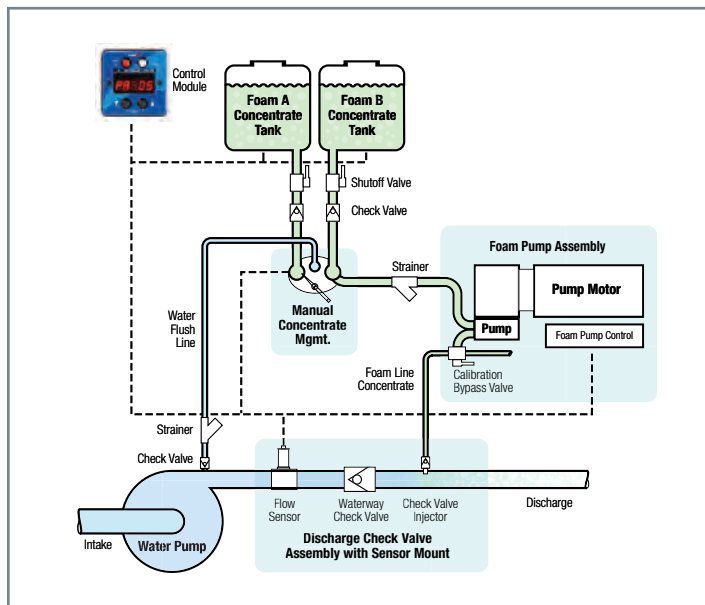

2000 Series with **Electronic Concentrate Mgmt System**

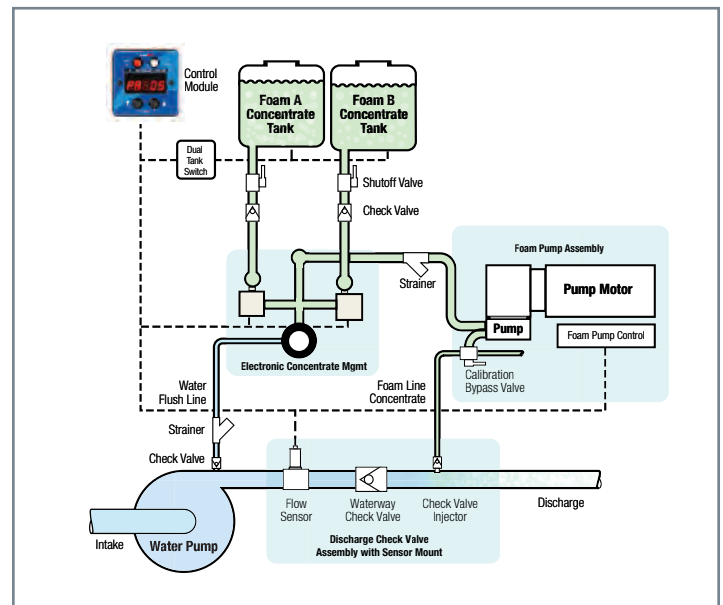

The Ultimate in Foam Technology



TurboFoam is a direct injection foam proportioning system that is available in several models with a variety of features, options, and accessories. With accurate foam proportioning for both Class A and/or Class B applications, TurboFoam provides an all-in-one design for complete foam management. The unique preset feature allows for simple foam operation while the integrated digital displays and smart features provide greater versatility. The foam pump assembly includes the pump and electric motor along with the foam pump control box. Six pump sizes are available: 1.6 GPM, 2.6 GPM, 5.0 GPM, 6.2 GPM, and 6.5 GPM (with 24 VDC systems only).

TurboFoam Series

(Class A and/or B Foam)

Ideal for use on:

- Municipal fire
- Brush fire
- Forestry fire fighting apparatus

System features and benefits:

- LED digital readout
- USB port interface
- Over 30 programmable codes
- Service reminders
- Pump pressure relief valve
- Foam tank low and empty warnings
- Time remaining for operation at current concentrate usage display

Control module features:

- On/Off button with LED indicator
- Flow rate display
- Electronic flush (TFC300/400 Only)
- Preset foam percent
- Foam percent display
- Push button control
- Dual tank selector (TFC 400 only)

Options:

- Manual ABF selector
- TankVision or tank float switch
- Discharge check valve assembly
- Remote ON/OFF switch
- Paddle wheel flow sensors



Optional TankVision & Manual ABF Selector pictured.

TurboFoam

A Solution For All Foam



TFC100

The simplest system, this control is for use with a single foam tank. A single 4-digit display and four LED indicators provide system information to the operator. A mode button is used to toggle the display to view foam percent, water flow, or flow totaling.



TFC200

Flexible programming allows this control to be used with a single foam tank or in a two foam tank system when the manual ABF selector option is installed.



TFC300

This control is for use with a single foam tank and includes an electric valve to provide electronic flush control. A flush button with an LED indicator on the control module operates the flush valve.



TFC400

This control is for use with two foam tanks and includes the 3-valve electric ABF selector to provide automatic electronic flush control. A flush button with LED indicator and an A/B button with foam A and foam B indicator LEDs on the control module operate the ABF selector.



5 Pump Sizes Get The Job Done

1.6 GPM, 2.6 GPM, 5.0 GPM, 6.2 GPM

6.5 GPM with 24 VDC systems only



Applications

Foam Innovations

The foam pump assembly includes the pump and electric motor along with the foam pump control box. The calibration bypass valve and a pressure relief valve are included as part of this assembly.

Triplex Plunger Pump

- Viton seals
- Die cast bodies
- Forged brass heads
- Solid ceramic plungers
- Oil level sight glass
- Oil reservoir vented cap/dip stick
- Oversized roller bearings
- Anodized cast cooling fins

Foam Pump Control

- Motor power input terminals
- Motor speed control circuits
- RPM sensor input
- System interface
- Sealed against water infiltration

Electric Motor

- Designed for use in wet environment
- Moisture-resistant interior components
- Durable white epoxy coating
- Endshield drains
- RPM sensor
- Stainless steel shaft
- Built-in cooling fan (3/4 & 1 HP motors only)

Pressure Relief Valve

- Factory set for 400 PSI (27.6 BAR)
- Adjustable when required

Calibration Bypass Valve

- Calibrated using operational concentrate
- Concentrate is returned to system, no waste

TurboFoam Interfaces with TankVision and Insight Ultimate via Datalink.

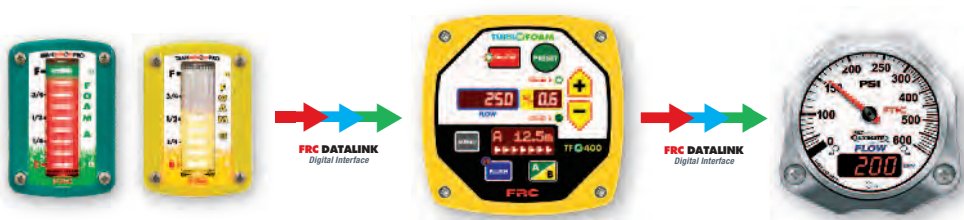

- Provides Accurate Monitoring of Foam Tank Volume
- Displays Low Foam Tank Warning
- Supplies Tank Empty Information
- Displays Time Remaining for Operation at Current Concentrate Usage
- Capable of Dual Tank Monitoring

TurboFoam

TurboFoam Series

Pump Sizes GPM (LPM) :	1.6 (6.06)	2.6 (9.84)	5.0 (18.93)	6.2 (23.47)	6.5 (24.61)
Motor Size (horsepower) :	1/3	1/2	1	1	1
DC Voltage :	12 or 24	12 or 24	12 or 24	12	24
Maximum Current (Amps) :	36 or 18	50 or 25	78 or 39	90	45
Maximum Operating Pressure PSI (Bar)	400 (27.6)	400 (27.6)	400 (27.6)	400 (27.6)	400 (27.6)

System Capacity

Foam Concentration	TFC16 Max. Water Flow GPM (LPM)	TFC26 Max. Water Flow GPM (LPM)	TFC50 Max. Water Flow GPM (LPM)	TFC62 Max. Water Flow GPM (LPM)	TFC65 Max. Water Flow GPM (LPM)
0.2%	800 (3,028)	1,300 (4,421)	2,500 (9,463)	3,100 (11,734)	3,250 (12,301)
0.5%	320 (1,211)	520 (1,968)	1,000 (3,785)	1,240 (4,694)	1,300 (4,921)
1.0%	160 (606)	260 (984)	500 (1,893)	620 (2,347)	650 (2,461)
3.0%	53 (202)	87 (328)	166 (628)	207 (782)	217 (820)
6.0%	27 (101)	43 (164)	83 (315)	103 (391)	108 (410)

TurboFoam Series Attack Capability

Class A Foam Concentration					
Maximum Coverage per Critical Application Rate (Iowa Formula)					
Foam Concentration	TFC16 Max. Water Flow cu.ft (cu.m)	TFC26 Max. Water Flow cu.ft (cu.m)	TFC50 Max. Water Flow cu.ft (cu.m)	TFC62 Max. Water Flow cu.ft (cu.m)	TFC65 Max. Water Flow cu.ft (cu.m)
0.2%	80,000 (2,265)	130,000 (3,681)	250,000 (7,079)	310,000 (8,778)	325,000 (9,203)
0.5%	32,000 (906)	52,000 (1,472)	100,000 (2,832)	124,000 (3,511)	130,000 (3,681)
1.0%	16,000 (453)	26,000 (736)	50,000 (1,416)	62,000 (1,756)	65,000 (1,841)

Class B Foam Concentration					
Hydrocarbon @ 0.10 gpm/sq.ft (0.37854 LPM/sq.m)					
Foam Concentration	TFC16 sq.ft (sq.m)	TFC26 sq.ft (sq.m)	TFC50 sq.ft (sq.m)	TFC62 sq.ft (sq.m)	TFC65 sq.ft (sq.m)
1.0%	1,600 (149)	2,600 (242)	5,000 (465)	6,200 (576)	6,500 (604)
3.0%	530 (49)	870 (81)	1,660 (154)	2,070 (192)	2,170 (202)
6.0%	270 (25)	430 (40)	830 (77)	1,030 (96)	1,080 (100)

Polar Solvent @0.20 gpm/sq.ft (0.757 LPM/sq.m)					
3.0%	265 (25)	435 (40)	830 (77)	1,035 (96)	1,085 (100)
6.0%	135 (13)	215 (20)	415 (39)	515 (48)	540 (50)

TurboFoam

Single Tank Systems

TFC100/TFC200

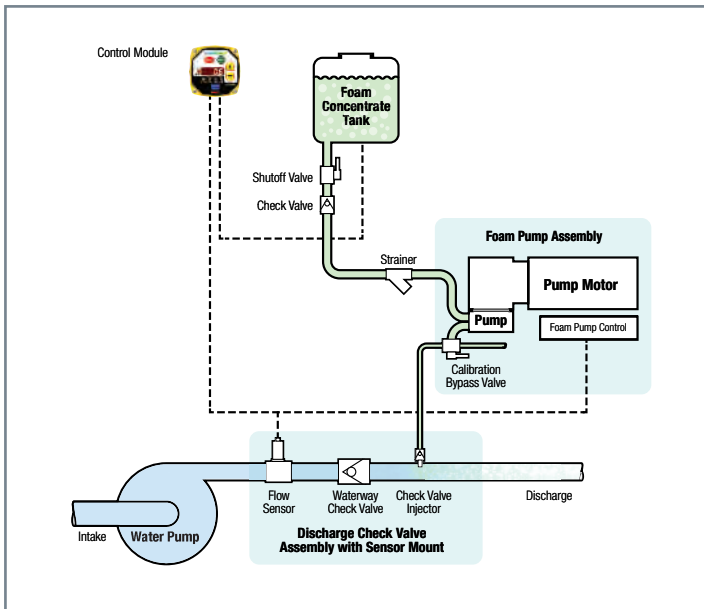

TFC100/TFC200 /TFC300 with Electric Flush Valve

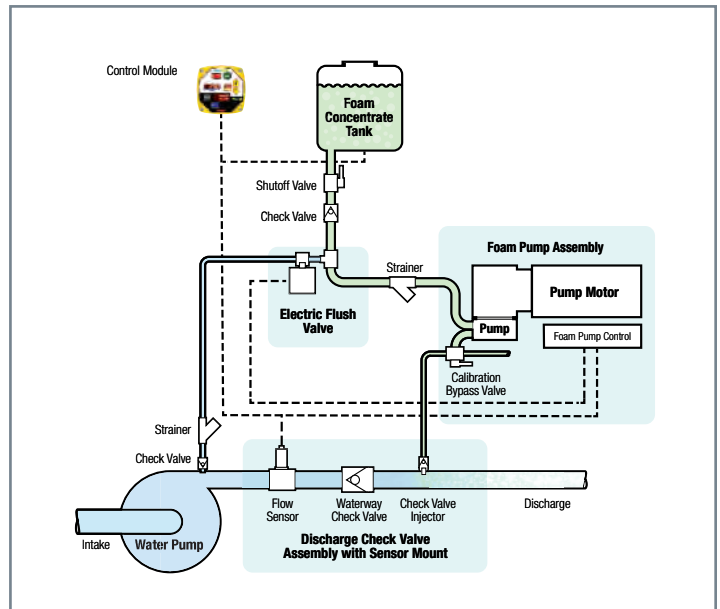

*TFC100/200 requires installation of a remote flush switch.

Dual Tank Systems

TFC200 with Manual ABF Selector

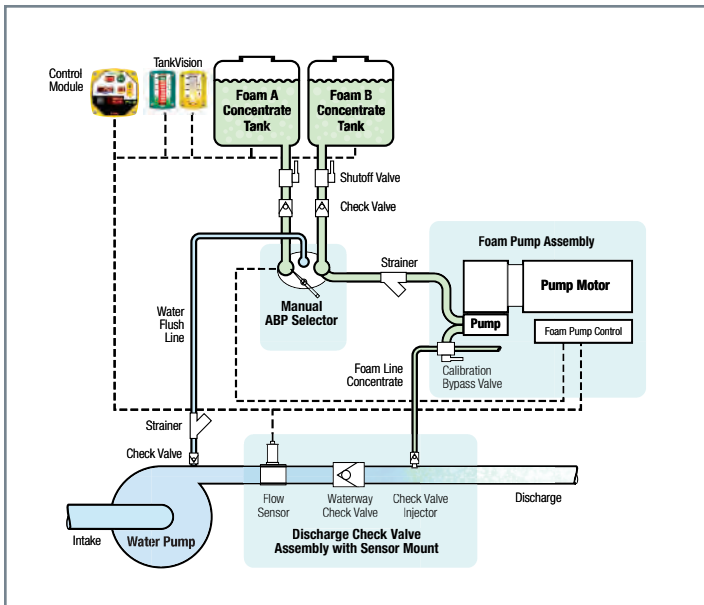

TFC400 with Electric ABF Selector

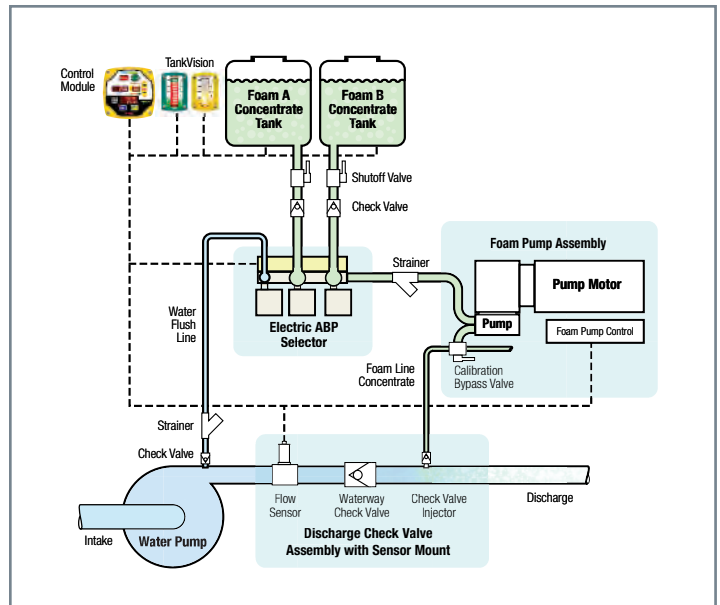

Direct Injection

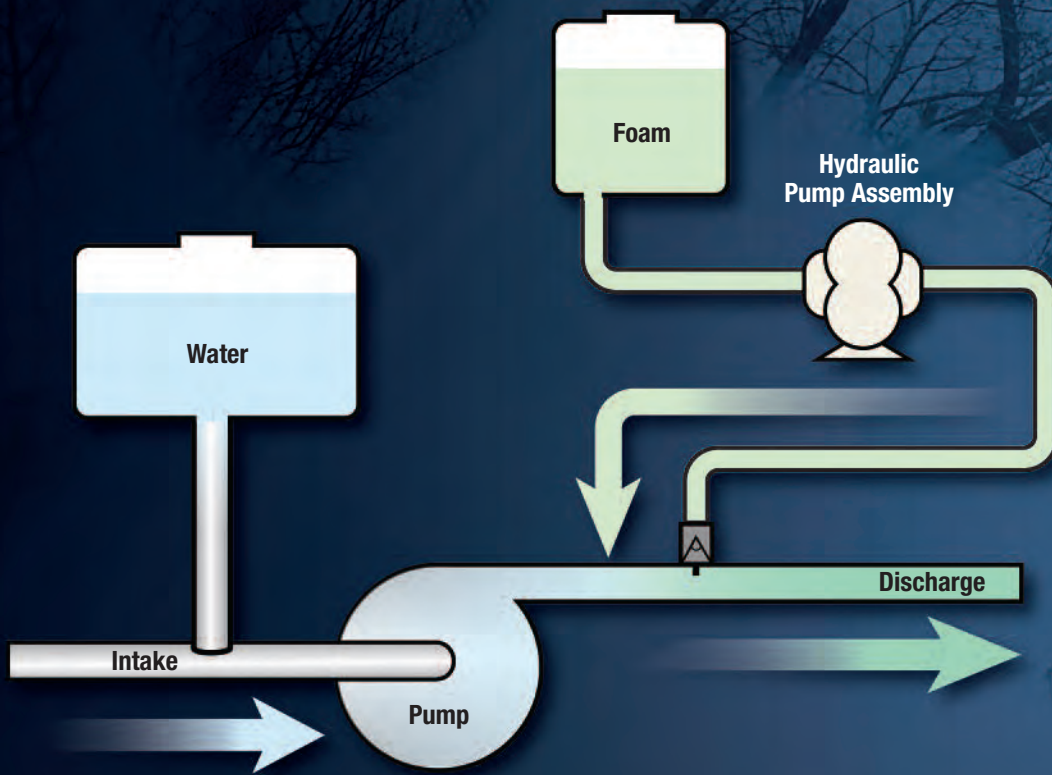

Direct injection foam proportioning systems add the foam concentrate downstream of the water pump. In this system, flushing of the water pump is not necessary.

on



Hydraulic Systems

FOAMPRO[®]

precision foam every time.



Greater Class A and Class B firefighting power is at your fingertips with the FoamPro Model 3012 proportioner. This versatile system delivers unmatched, supercharged performance with concentrate flow from 0.1 to 12.0 gpm at 0-400 psi, all from a single pump. High drafting capabilities allow off-board pickup for foam operations or tank refill, which is crucial for higher flow demands or when changing concentrates. Unlike other pump designs that may pause in flow during operation, FoamPro's triplex plungers are timed to discharge one after the other delivering smooth, continuous injection. The hydraulic pump drive and microprocessor control technology delivers extremely accurate concentrate injection from minimum flow to full capacity. The system includes the same industry-proven, ultra-bright LED digital display/control module used on FoamPro 2000 series proportioning systems.

3012 Series

(Class A and/or B Foam)

Ideal for use on:

- Municipal pumpers
- Aerials
- Marine and shipboard systems
- Compressed Air Foam Systems

System features and benefits:

- Fully automatic-on demand
- Discharge side injection
- No in-line restrictions, greater flow
- Unmatched accuracy over the widest range of flow
- Smoothest proportioning available at ultra-low flow
- Leading the industry in proven reliability
- Proportions continuously, with no stopping to refill
- Industry's highest capacity Class A/B system
- Variable displacement hydraulic pump
- Delivers 0.1 to 12.0 gpm (0.38 - 45.4 L/min)
- Injection pressure to 400 psi (27.6 BAR)
- Achieves full pump capacity with all known Class A, Class B AFFF and most Class B AR-AFFF
- Installs easily in new or existing apparatus

Control module features:

- Ultra-bright LED digital readout
- Injection percentage from 0.1% to 10.0%
- Display following information:
 - Low concentrate/ No concentrate warning
 - Water flow rate
 - Total water used
 - Injection percentage
 - Total concentrate used
- Dual-tank capability
- Displays separate totals for each tank
- Calibrate for each concentrate

Options:

- Concentrate management systems
- Advanced feature controller - auto on
- MultiFlo
- Remote start/stop for pump and roll applications
- Dual-Injection selector
- Solid state contactor
- Flow sensors, check valves, manifolds
- Low-Level sensors
- Manual Override
- Single tank and off-board pickup



Low-level sensor, flow sensor & check valve pictured.

Series

3012

Model 3012

Foam Pump:	Triplex Plunger
Foam Output GPM : (L/min) @ 200 psi	0.1-12.0 (0.38-45.4)
Maximum Operating Pressure PSI (BAR):	400 (27.6)
Maximum Operating Temperature °F (°C):	160 (71)
Pump Motor:	Hydraulic
Hydraulic Supply Oil Pressure PSI (BAR):	1,250 (86.2)
Hydraulic Supply Oil Flow GPM (L/min):	12 (45.4)
Maximum Amp Draw:	5

System Capacity

Foam Concentration	Maximum Water Flow GPM (L/min)	Foam Concentration	Maximum Water Flow GPM (L/min)
0.2%	6,000 (22,771)	1.0%	1,200 (4,542)
0.3%	4,000 (15,140)	3.0%	400 (1,514)
0.5%	2,400 (9,084)	6.0%	200 (757)

Model 3012 Attack Capacity

Class A Foam Concentration	3012 Maximum Coverage per Critical Application Rate (Iowa Formula) cu.ft (cu.m)
0.2%	600,000 (16,990)
0.5%	240,000 (6,796)
1.0%	120,000 (3,398)

Class B Foam Concentration	Hydrocarbon @ 0.10 gpm/sq.ft (0.37854 LPM/sq.m) sq.ft (sq.m)
1.0%	12,000 (1,114)
3.0%	4,000 (371)
6.0%	2,000 (185)
Polar Solvent @ 0.20 gpm/sq.ft. (0.757 LPM/sq.m)	
3.0%	2,000 (185)
6.0%	1,000 (92)

Series 3012

System Diagram

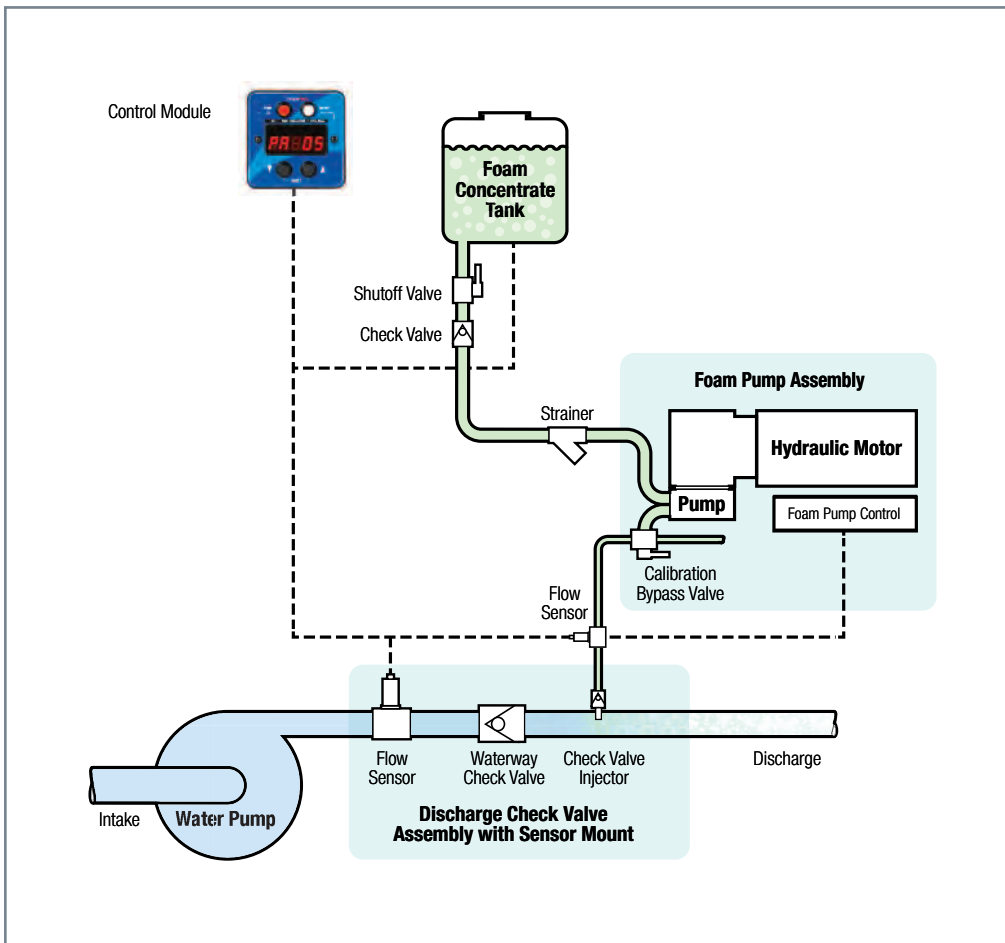

AccuMax[®] Series

Single-Point Injection

Multi-Point Injection

Is accuracy critical? Let's assume you are treating just 5000 gpm at 3% with older technology that is 30% inaccurate. Your concentrate requirements would be 150 gpm plus 45 gpm of inaccuracy. At \$20 per gallon, your additional cost is \$900 per minute. In addition, your logistical efforts will require movement of the additional concentrate or 195 gpm total. Multiply these totals by incident time to determine your true cost.

AccuMax® Series

Big water flow requires dependable, accurate and easy to use foam proportioning. AccuMax, the industry's first high-volume, on-demand, direct injection system, sets new standards for industrial foam management systems. By incorporating the most advanced microprocessor-driven control and measurement technologies, the AccuMax series of proportioners delivers unmatched accuracy with extreme ease. At the push of a button, these hydraulically-powered systems measure water flow and automatically inject the desired amount of foam concentrate; all with pinpoint precision.

In addition, greater performance is achieved at the nozzle as flow sensor technology doesn't restrict flow like eductors and ratio controllers. The true flow-based operation allows unlimited placement of the apparatus, meaning increased safety with positioning further from the incident. All AccuMax systems utilize industry-proven and dependable rotary gear foam pumps. High drafting capabilities allow off-board pickup for foam operations or tank refill, which is crucial for higher flow demands or when changing concentrates.

Calibration and tests are performed without mixing concentrate with water, saving thousands of dollars in wasted concentrate over the life of the vehicle. This system is truly environmentally green as reclamation of foam solution is not required.

Available in either single- or multi-point injection and with capacities to 300 gpm (1135 L/min), AccuMax delivers extreme foam concentrate for any "Big Flow" application. When your large, high value assets are at risk, AccuMax is the system you want for their protection.

AccuMax



Low-level sensor, flow sensor, and check valve. Available with Fire Lion Global pump or Trident Titan™ pump (top).

AccuMax® Single-Point

	3020	3040	3060	3090	3150	3300
Minimum Foam Output GPM (LPM):	4.0 (15)	4.0 (15)	5.0 (23)	6.0 (23)	10.0 (38)	12.0 (45)
Maximum Foam Output GPM (LPM):	40 (76)	40 (151)	60 (227)	90 (341)	150 (568)	300 (1,136)
Maximum Operating Pressure PSI (BAR):	300 (20.7)	300 (20.7)	300 (20.7)	300 (20.7)	300 (20.7)	300 (20.7)
Maximum Hydraulic Oil Pressure PSI (BAR):	1,734 (119.6)	2,649 (182.6)	3,484 (240.2)	4,479 (308.8)	4,378 (301.9)	5,873 (404.9)
Maximum Hydraulic Oil Flow GPM (LPM):	16.8 (63.6)	16.3 (61.7)	22.9 (86.7)	23.7 (89.7)	29.5 (111.7)	47.4 (179.4)
Maximum Amp Draw:	5	5	5	5	5	5

Note : Lower minimum flow attainable with low flow option.

System Capacity

Foam Concentration	Maximum Water Flow GPM (LPM)					
	3020	3040	3060	3090	3150	3300
1.0%	2,000 (7,571)	4,000 (15,140)	6,000 (22,700)	9,000 (34,069)	15,000 (56,781)	30,000 (113,563)
3.0%	666 (2,521)	1,333 (5,046)	2,000 (7,571)	3,000 (11,356)	5,000 (18,927)	10,000 (37,854)
6.0%	333 (1,261)	666 (2,521)	1,000 (3,785)	1,500 (5,678)	2,500 (9,464)	5,000 (18,927)

AccuMax® Single-Point Performance

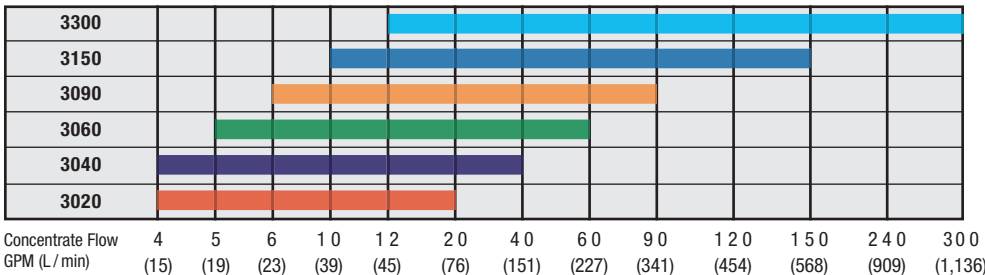

Standard

Maximum Operating Pressure PSI (BAR): 300 (20.7)

Maximum Operating Temperature °F (°C): 160 (71)

Maximum Amp Draw: 5

System Diagram

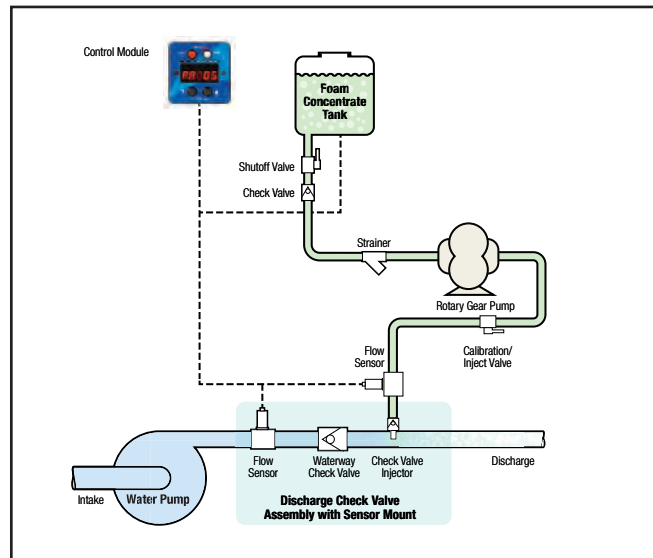

AccuMax[®] Single-Point Injection

(Class B Foam Only)

Ideal for use on:

- Industrial pumpers
- Industrial aerials
- Marine and shipboard systems

Designed and engineered specifically for applications requiring a single, high flow foam solution. Class B firefighting power is at your fingertips via the same industry-proven, digital display/control module used on FoamPro 2000 series systems. AccuMax single-point injection systems measure water flow in a common manifold and inject according to operator settings. All foam-capable discharges flow solution at the same percentage. Injection percentage is automatic with programmable default settings or easily changed at the push of a button. Real time flow and performance information is displayed by ultra-bright LED readouts.

System features and benefits:

- Fully automatic-on demand
- Discharge side injection
- No in-line restrictions, greater flow
- Unmatched accuracy over the widest range of flow
- Leading the industry in proven reliability
- Calibrate and test without mixing concentrate
- Industry's highest capacity system
- Increased safety - Unlimited placement
- Delivers up to 300 gpm (1135 L/min)
- Injection pressure to 300 psi (20.7 BAR)
- Achieves full pump capacity with all known Class B concentrate
- Excellent draft capability for off-board supply
- Fire Lion Global pump standard

Control Module Features

- Ultra-bright LED digital readout
- Injection percentage from 0.1% to 10.0%
- Display following information:
 - Low concentrate/ no concentrate warning
 - Water flow rate
 - Total water used
 - Injection percentage
 - Total concentrate used
- Dual-foam supply capability
- Displays separate totals for each tank
- Calibrate for each concentrate

Options

- Advanced Feature Controller - Auto On
- MultiFlo
- Remote Start/Stop
- Flow sensors, check valves, manifolds
- Solid State Contactor
- Fire Lion Edwards Pump
- Titan Pentair Aurora[®] Pump
- Low-Level Sensors
- ManualOverride
- Edwards Foam Pump
- Trident Titan[™] Pump



Low-level sensor, flow sensor & check valve pictured. Fire Lion Global pump.

AccuMax

AccuMax® Multi-Point

	3040	3060	3090	3150	3300
Minimum Foam Output GPM (LPM):	4.0 (15)	5.0 (19)	6.0 (23)	6.0 (23)	10.0 (38)
Maximum Foam Output GPM (LPM):	40 (151)	60 (227)	90 (341)	150 (568)	300 (1,136)
Maximum Operating Pressure PSI (BAR):	300 (20.7)	300 (20.7)	300 (20.7)	300 (20.7)	300 (20.7)
Maximum Hydraulic Oil Pressure PSI (BAR):	2,649 (182.6)	3,484 (240.2)	4,479 (308.8)	4,378 (301.9)	5,873 (404.9)
Maximum Hydraulic Oil Flow GPM (LPM):	16.3 (61.7)	22.9 (86.7)	23.7 (89.7)	29.5 (111.7)	47.4 (179.4)
Maximum Amp Draw:	5	5	5	5	5

Note : Lower minimum flow attainable with low flow option.

System Capacity

Foam Concentration	Maximum Water Flow GPM (LPM)				
	3040	3060	3090	3150	3300
1.0%	4,000 (15,140)	6,000 (22,700)	9,000 (34,069)	15,000 (56,781)	30,000 (113,563)
3.0%	1,333 (5,046)	2,000 (7,571)	3,000 (11,356)	5,000 (18,927)	10,000 (37,854)
6.0%	666 (2,521)	1,000 (3,785)	1,500 (5,678)	2,500 (9,464)	5,000 (18,927)

AccuMax® Multi-Point Performance

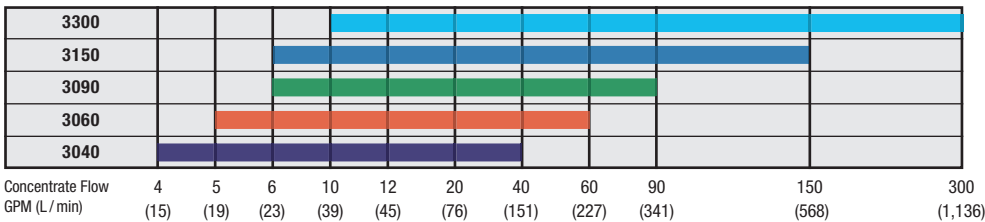

Standard

Maximum Operating Pressure PSI (BAR): 300 (20.7)
 Maximum Operating Temperature °F (°C): 160 (71)
 Maximum Amp Draw: 5

System Diagram

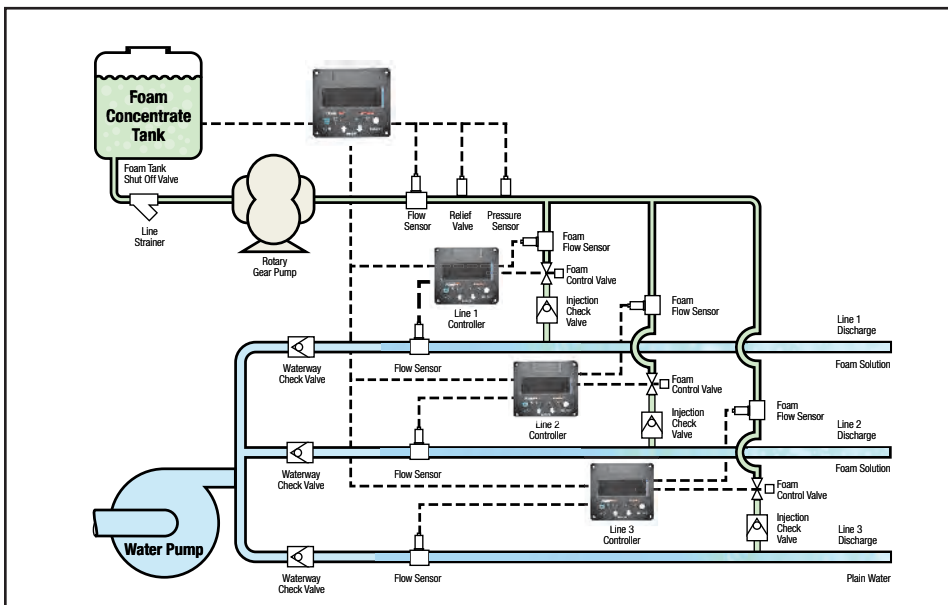

AccuMax[®] Multi-Point Injection

(Class B Foam Only)

Ideal for use on:

- Industrial pumpers
- Industrial aerials
- Marine and shipboard systems

Multi-point injection is designed specifically for high flow applications requiring different foam solution mixtures at each foam-capable outlet. A simple push of the digital master control “ON” button activates the system’s electronics and engages the hydraulically-driven concentrate pump. The master control manages overall performance as it receives information based on water flow and foam requirements from each discharge. A digital control module at each outlet allows the operator to choose between plain water or solution. If foam is required, proportioning is automatic, based on programmable default injection percentage. Injection rates are easily changed at the push of a button. Each control module displays real time flow and performance information by ultra-bright LED readouts.

System features and benefits:

- Fully automatic-on demand
- Up to ten individual discharge controls
- Choice of percentage at each discharge
- Multi-point, discharge side injection
- No in-line restrictions, greater flow
- Unmatched accuracy over the widest range of flow
- Leading the industry in proven reliability
- Calibrate and test without mixing concentrate
- Industry’s highest capacity system
- Increased safety - Unlimited placement
- Delivers up to 300 gpm (1135 L/min)
- Injection pressure to 300 psi (20.7 BAR)
- Achieves full pump capacity with all known Class B concentrate
- Excellent draft capability for off-board supply
- Fire Lion Global pump standard

Control Module Features

- Ultra-bright LED digital readout
- Injection percentage from 0.1% to 25.0%
- Display following information:
 - Low concentrate/ No concentrate warning
 - Water flow rate
 - Total water used
 - Injection percentage
 - Total concentrate used
- Advanced Feature Controller - Auto On
- Diagnostic modes

Options

- Individual pressure readings
- Low Flow options
- Manual override
- Solid state contactor
- Flow sensors, check valves, manifolds
- Individual line control sized to meet specific flow requirements
- Edwards Foam Pump
- Trident Titan™ Pump



Individual line controllers, flow sensor & check valve pictured. Fire Lion Global pump.

AccuMax

Around The Pump

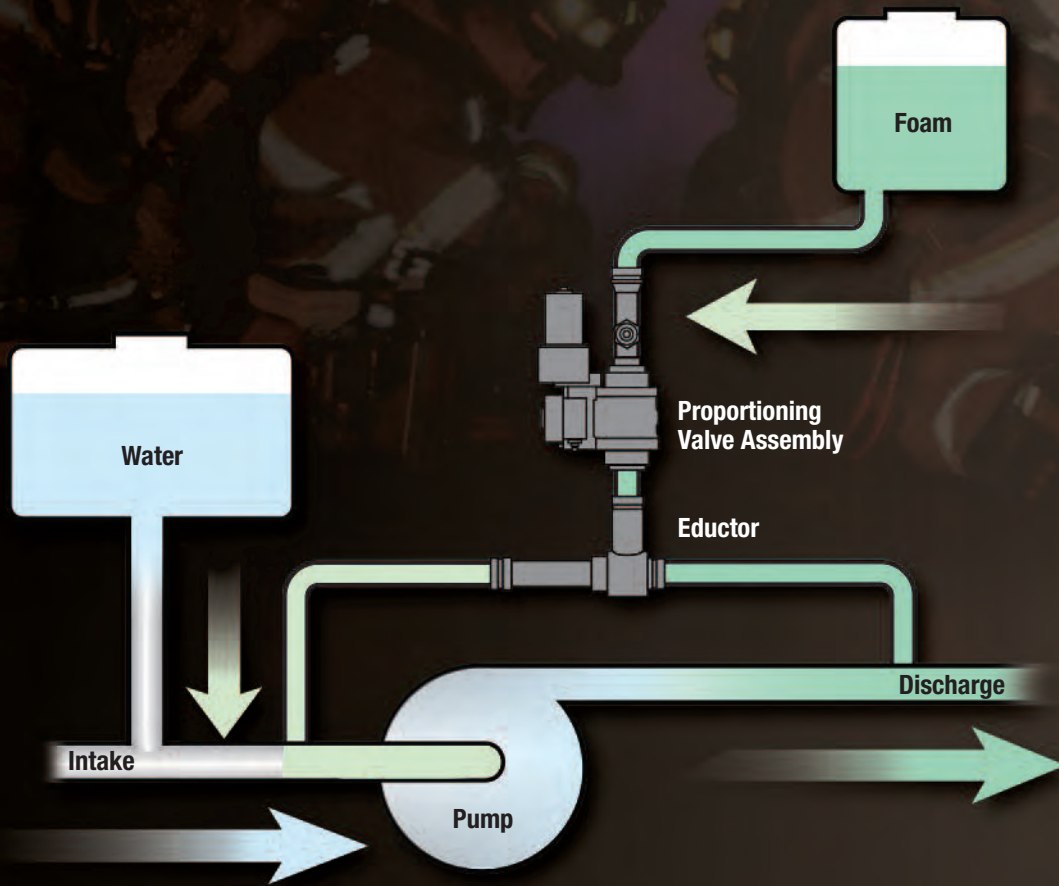

These systems do not require a foam concentrate pump, which will reduce maintenance over the life of the vehicle. When the foam system is activated, the foam concentrate will be drawn into the suction side of the pump, allowing the solution to be discharged. Around the Pump systems allow for very large foam discharge rates at a more economical cost.

ump

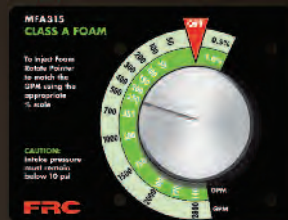

Automatic / Manual Systems

FOAMPRO®

precision foam every time.

Foam Output

Foam Concentration	FSB015	FSB030	FSB060	FSB120	FSB240
Max. flow rate in GPM	15	30	60	120	240

System Capacity

Foam Concentration	FSB015 Maximum Water Flow GPM (L/min)	FSB030 Maximum Water Flow GPM (L/min)	FSB060 Maximum Water Flow GPM (L/min)	FSB120 Maximum Water Flow GPM (L/min)	FSB240 Maximum Water Flow GPM (L/min)
1.0%	1,500 (5,678)	3,000 (11,355)	6,000 (22,710)	12,000 (45,420)	24,000 (90,840)
3.0%	500 (1,893)	1,000 (3,785)	2,000 (7,570)	4,000 (15,141)	8,000 (30,283)
6.0%	250 (946)	500 (1,892)	1,000 (3,785)	2,000 (7,570)	4,000 (15,141)

AutoFoam SC Attack Capability

Class B Foam Concentration					
Hydrocarbon @ 0.10 gpm/sq.ft (0.37854 LPM/sq.m)					
Foam Concentration	FSB015 sq.ft (sq.m)	FSB030 sq.ft (sq.m)	FSB060 sq.ft (sq.m)	FSB120 sq.ft (sq.m)	FSB240 sq.ft (sq.m)
1.0%	15,000 (1,394)	30,000 (2,787)	60,000 (5,574)	120,000 (11,148)	240,000 (22,297)
3.0%	5,000 (465)	10,000 (929)	20,000 (1,858)	40,000 (3,716)	80,000 (7,432)
6.0%	2,500 (232)	5,000 (465)	10,000 (929)	20,000 (1,858)	40,000 (3,716)

Class B Foam Concentration					
Polar Solvent @ 0.10 gpm/sq.ft (0.757 LPM/sq.m)					
Foam Concentration	FSB015 sq.ft (sq.m)	FSB030 sq.ft (sq.m)	FSB060 sq.ft (sq.m)	FSB120 sq.ft (sq.m)	FSB240 sq.ft (sq.m)
3.0%	2,500 (232)	5,000 (465)	10,000 (929)	20,000 (1,858)	40,000 (3,716)
6.0%	1,250 (116)	2,500 (232)	5,000 (465)	10,000 (929)	20,000 (1,858)

System Diagram

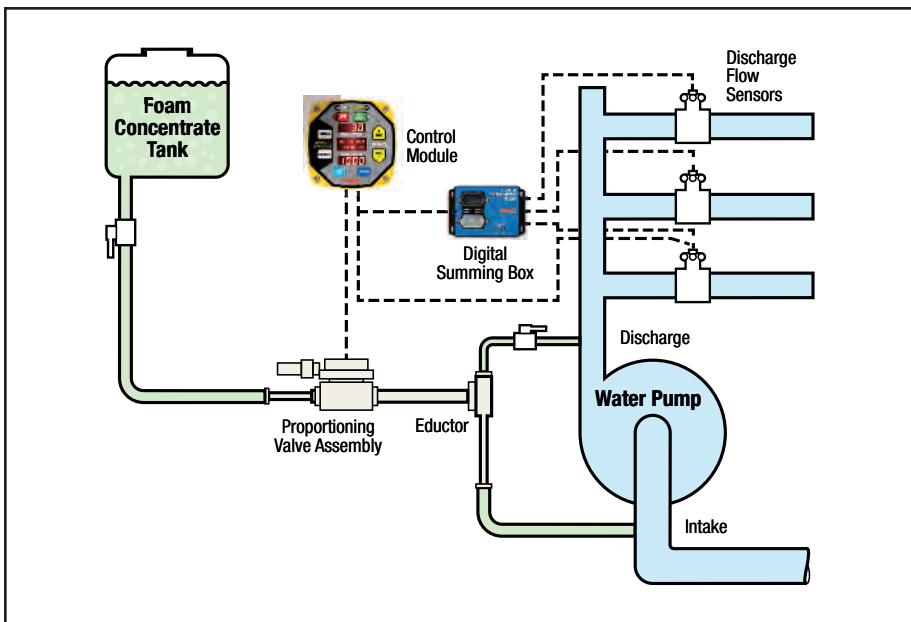

AutoFoam Series

Complete automatic proportioning for Class B foam

Ideal for use on:

- Municipal Fire Apparatus
- Airport Rescue and Fire Fighting Apparatus
- Industrial Fire Apparatus
- Compressed Air Foam Systems

The AutoFoam around-the-pump system provides complete automatic proportioning for Class B foam. The operator selects a foam percent mixture and the solution provides a consistent foam solution at all discharges regardless of water flow fluctuations. A microprocessor controls the proportioning valve to automatically maintain accurate control over foam concentrate flow rates. The operator can override automatic operation by using the manual override buttons to control the proportioning valve. All operations, programming, and calibration are accomplished using the control module. Calibration for the system is stored in memory on each of the major components. This allows for the replacement of components without recalibration of the system.

System features

- Push button control
- Flow totaling for both foam concentrate and water
- Powers-up at the previous proportioning percent
- Manual override
- Remote Auto/Off switch (Optional)
- Built-in diagnostics

Control module features

- Current water flow
- Total amount of foam concentrate flow
- Foam concentrate left in tank (input required from TankVision display)
- Percent the valve is open
- Stored faults with date and time using the INC and DEC buttons to scroll

Options

- Multiple discharge sensors
- Flow rates displayed in LPM
- Remote Auto/Off switch

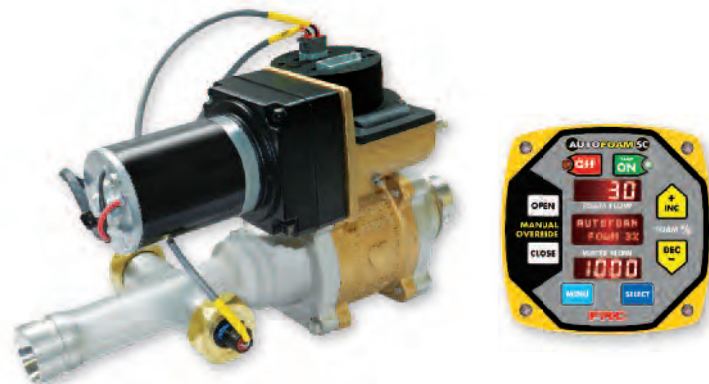

AutoFoam

System Capacity

Foam Concentration	MFA200 Maximum Water Flow GPM (L/min)	MFA201 Maximum Water Flow GPM (L/min)	MFA220 Maximum Water Flow GPM (L/min)		MFA315 Maximum Water Flow GPM (L/min)	MFA342 Maximum Water Flow GPM (L/min)	MFA320 Maximum Water Flow GPM (L/min)	
	Class A	Class B	Class A	Class B	Class A	Class B	Class A	Class B
0.25%	2,000 (7,570)	N/A	2,000 (7,570)	N/A	N/A	N/A	N/A	N/A
0.5%	1,000 (3,785)	N/A	1,000 (3,785)	N/A	3,000 (11,356)	N/A	3,000 (11,356)	N/A
1.0%	500 (1,892)	N/A	500 (1,892)	N/A	1,500 (5,678)	N/A	1,500 (5,678)	N/A
3.0%	N/A	1,000 (3,785)	N/A	1,000 (3,785)	N/A	1,400 (5,299)	N/A	1,400 (5,299)
6.0%	N/A	500 (1,892)	N/A	500 (1,892)	N/A	700 (2,649)	N/A	700 (2,649)

Manual Foam SC Attack Capability

Class A Foam Concentration				
Maximum Coverage per Critical Application Rate (Iowa Formula)				
Foam Concentration	TFC16 Max. Water Flow cu.ft (cu.m)	TFC26 Max. Water Flow cu.ft (cu.m)	TFC35 Max. Water Flow cu.ft (cu.m)	TFC65 Max. Water Flow cu.ft (cu.m)
0.25%	200,000 (5,663)	200,000 (5,663)	N/A	N/A
0.5%	100,000 (2,831)	100,000 (2,831)	300,000 (8,495)	300,000 (8,495)
1.0%	50,000 (1,415)	50,000 (1,415)	150,000 (4,247)	150,000 (4,247)

Class B Foam Concentration				
Hydrocarbon @ 0.10 gpm/sq.ft (0.37854 LPM/sq.m)				
Foam Concentration	MFA201 sq.ft (sq.m)	MFA220 sq.ft (sq.m)	MFA342 sq.ft (sq.m)	MFA320 sq.ft (sq.m)
3.0%	10,000 (929)	10,000 (929)	14,000 (1,300)	14,000 (1,300)
6.0%	5,000 (465)	5,000 (465)	7,000 (650)	7,000 (650)

Polar Solvent @0.20 gpm/sq.ft (0.757 LPM/sq.m)				
Foam Concentration	MFA201 sq.ft (sq.m)	MFA220 sq.ft (sq.m)	MFA342 sq.ft (sq.m)	MFA320 sq.ft (sq.m)
3.0%	5,000 (465)	5,000 (465)	7,000 (650)	7,000 (650)
6.0%	2,500 (232)	2,500 (232)	3,500 (325)	3,500 (325)

System Diagram

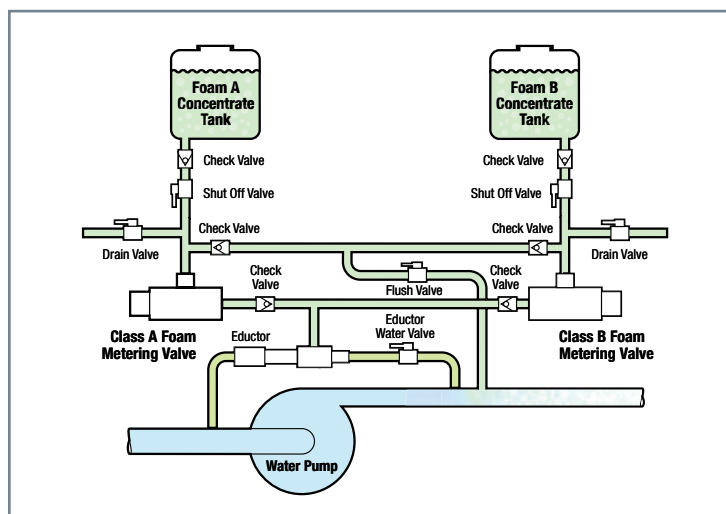

Manual Foam Series

Manual proportioning for Class A or B foam

Many departments may not be able to justify the cost of a complicated electronic foam system. A simple and cost effective way to provide your fire fighting vehicles with Class A and/or Class B foam is with an around-the-pump, manual foam system like this. Specially engineered, highly efficient eductors and laser cut metering valve orifices are the key to these high performance systems. Many manual systems on the market today can't deliver foam at these rates.

System Features

- Economical foam system provides the most foam for the lowest cost
- Operator selected setting for correct foam flow in seconds
- Adjusts foam up or down quickly for all situations
- Wide operating range
- Proven reliable for high flow operations

MFA200 Series Panel features

- Printed table on the face of the unit helps determine the required value setting
- Class A Foam System metering valve provides foam proportioning of 1/4%, 1/2%, and 1%.
- Class B Foam System metering valve provides foam proportioning of 3% and 6%.

MFA300 Series Panel features

- The required valve setting is simply set by adjusting the control knob to the discharge water flow (no table to reference).
- Class A Foam System metering valve provides foam proportioning of 1/2%, and 1%.
- Class B Foam System metering valve provides foam proportioning of 3% and 6%.

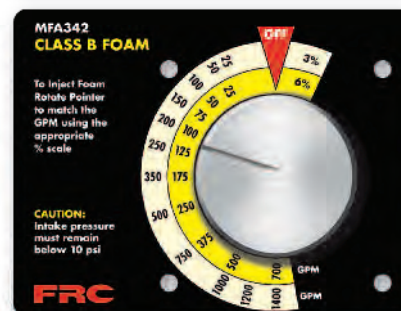
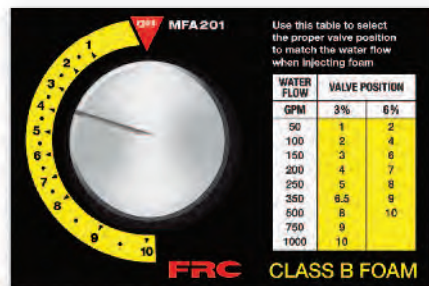
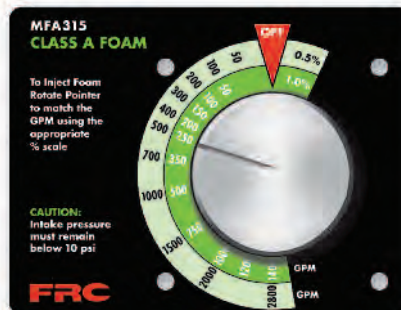
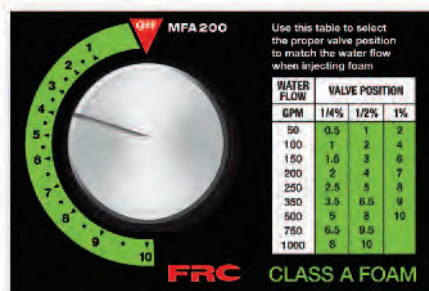

Specialty Foam



m



Mobile / Fill Systems

FOAMPRO[®]

precision foam every time.

ULTRA HIGH PRESSURE MOBILE FOAM SYSTEM



Compact and self-contained, the Turbo Stream produces high energy firefighting power with ease and precision. Available with PowerPro™ brand, or Honda gas engine drives. While other systems use inaccurate suction side eductors, Turbo Stream incorporates a patented foam concentrate injector system. The control module allows the operator to choose injection rates, from 0.3% to 3.0%, with unmatched accuracy, exceeding NFPA 1901 requirements.

Turbo Stream®

Ideal for use on:

- Brush rigs
- ATV/RTV utility apparatus
- Fast attack vehicles
- Wildland trucks

Combined Features and Benefits:

- Delivers 8 gpm (30 L/min) of solution @ 1400 psi (96.5 BAR)
- Triplex plunger pump provides dependability and high pressure performance
- Ideal for use with all Class A concentrates
- Adjustable control provides unmatched accuracy over the widest range of flow
- Dual-action spray gun delivers foam solution over 45 feet (13 meters)
- Thermal relief valve prevents overheating during extended idle
- Installs easily in new or existing apparatus
- Capable of drafting water up to 6'(1.8M) and foam to 3'(.9M)

System Includes:

- Dual-Action spray gun
- PowerPro™ electric start or Honda electric start
- Triplex plunger pump
- Precision foam control 0.3% - 3.0%
- Concentrate injector
- Intake check valve
- Over-Pressure protection
- Low-Oil sensor

Control Module Features:

- Foam percentage selector
- Injection percentage from 0.3% to 3.0%
- Visual foam flow confirmation

Options:

- Foam tanks available in 8,12,20 gallons (30, 45, 75 liters)
- Low pressure gun tips
- Custom flows and pressures

Drive Options:

- PowerPro™ electric-start gas engine
- Honda electric-start gas engine



Turbo Stream

FOAM TANK REFILL SYSTEM



FoamPro, the industry leader, offers two refill systems, truck-mounted (12 or 24 VDC/240) and a portable 110/240 AC, that perfectly complement foam operations on your apparatus. Power-Fill is an electronically-controlled, pre-plumbed, self-priming, concentrate refill system that will save you time and increase the safety of your firefighters. With the simple push of a button or switch, our refill systems quickly reload on-board foam cells without messy spillage. Most importantly, Power-Fill safely eliminates awkward and strenuous lifting of concentrate containers and allows easier transfer from totes. These systems will fill even the largest tanks quickly and efficiently. The high drafting, non-corrosive pump, is compatible with all concentrates and viscosities currently used.

POWER-FILL™

Truck-Mounted System

12 or 24 VDC. Capable to 11 gpm (41 l/min)

The system operates by attaching a suction hose to a pre-plumbed panel connection using a cam-lock fitting. The pick-up wand is then placed in the concentrate container. The operator simply pushes a button to engage the pumping system, which automatically fills and stops when the tank is full. An indicator light notifies the operator that the operation is complete. Even though the system recognizes a full cell, the manual override feature will engage the concentrate pump momentarily, allowing the operator to fully empty the container. System is equipped with fresh water-flush capabilities.

System includes:

- High-capacity concentrate pump
- Continuous-duty 12 or 24 VDC motor
- Electronic microprocessor control
- Flush valve and panel plate
- 1" concentrate pick-up wand and 6' (1.8 M) suction hose

Portable System AC systems

110/240 AC capable of up to 18 gpm (68 l/min) for station use

The portable system is a remote operation that utilizes pre-plumbed, on-board piping. Connection of the discharge hose to the foam inlet is made with a cam-lock fitting. The pick-up wand on the suction side of the pump is placed in the concentrate container. To initiate refill, operator depresses momentary switch to engage the 110/240 AC pump. The tank is automatically filled and provides visual indication when complete. Carrying handle allows ease of transportation within the station or in the field.

System includes:

- High-capacity concentrate pump
- Continuous duty 110/240 AC motor with carrying handle
- GFI electrical cord with momentary switch
- Panel plate
- Indicator light
- Stainless fittings and cap
- 1" concentrate pick-up wand and 6' (1.8 M) suction hose

Combined Features and Benefits:

- Increased firefighter safety
- Saves time for team members
- Indicators provide system status
- Conveniently-mounted connections and controls
- Easily handles all concentrates
- Automatic system incorporates flush mode
- Compatible with all size totes and containers
- System reliability from a proven industry leader
- 9-10' (2.7M to 3M) lift capability



Note: To avoid contamination, apparatus with multiple concentrate cells require a pumping system for each tank.

POWER-FILL

Specifying a 1600, 2000, 3012, or AccuMax® System

Your maximum and minimum flows and pressures for all discharges supplied with foam.	Example: Maximum: One deck gun: 500 gpm (1893 L/min) at 150 psi (10.3 BAR) Minimum: One 1-1/2" line flowing 35 gpm (132.5 L/min) (mop-up), = 35 gpm (132.5 L/min) at 100 psi (6.9 BAR)
Determine the maximum and minimum foam concentrate levels that must be provided.	Example: Maximum: 1.0% AFFF Minimum: 0.5% Class A
Determine the size of the proportioner needed.	Example: Maximum Concentrate Requirement = maximum flow x maximum concentration 500 gpm (1893 L/min) x 1.0% = 5.0 gpm (18.9 L/min) Example: Minimum Concentrate Requirement = minimum flow x minimum concentration 35 gpm (132.5 L/min) x 0.5% = 0.18 gpm (.68 L/min) Therefore, the FoamPro system must be capable of delivering 0.18 to 5.0 gpm (.68 - 18.9 L/min) of concentrate. According to the performance curve, the Model 2002 will meet these requirements.
Determine if the flow sensor and flow sensor tee for the plumbing size being used will cover the range of flows in the first step.	Example: A 3" diameter pipe will be used to supply these discharges. The 3" flow sensor will accurately read between 30 gpm (113.6 L/min) and 1,150 gpm (4,353 L/min). The required range is 35 gpm to 500 gpm (132.5 - 1,893 L/min). Therefore, one flow sensor in a 3" tee will handle the requirements. If the flows should exceed the capacity of the flow sensor tee, then the installation would require two or more appropriate size flow sensors and a MultiFlo.

Flow Sensor Tee



UNRESTRICTED FLOW

Assy. Part Number	Size Tee (NPT)	Maximum Accuracy Flow Range	Maximum Operating Flow Range
2660-0030*	1-1/2"	5-110 gpm (19-416 L/min)	3-145 gpm (11.4-549 L/min)
2660-0031	1-1/2"	10-320 gpm (37.9-1,211 L/min)	3-380 gpm (11.4-1,438 L/min)
2660-0032	2"	15-520 gpm (56.8-1,968 L/min)	5-625 gpm (19-2,366 L/min)
2660-0033	2-1/2"	20-750 gpm (75.7-2,839 L/min)	8-900 gpm (30.3-3,407 L/min)
2660-0034	3"	30-1150 gpm (113.6-4,353 L/min)	12-1380 gpm (45.4-5,224 L/min)
2660-0035	4"	55-1980 gpm (208.2-7,495 L/min)	20-2380 gpm (75.7-9,009 L/min)

*1" I.D. bore

Manifold w/ Check Valve



Assy. Part Number	Size Tee (NPT)	Maximum Accuracy Flow Range	Maximum Operating Flow Range
2660-0051	1-1/2"	10-320 gpm (38-1,211 L/min)	3-380 gpm (11-1,438 L/min)
2660-0052	2"	15-520 gpm (57-1,968 L/min)	5-625 gpm (19-2,366 L/min)
2660-0053	2-1/2"	20-750 gpm (76-2,839 L/min)	8-900 gpm (30.3-3,407 L/min)
2660-0054	3"	30-1150 gpm (114-4,353 L/min)	12-1380 gpm (45-5,224 L/min)
2660-0055	4"	55-1980 gpm (208-7,495 L/min)	20-2380 gpm (75-9,010 L/min)

Insertion Style Flow Sensor



Assy. Part Number	Material	
2660-0044	Bronze Construction	
2660-0059	Stainless Steel Construction	
Pipe Size	Maximum Accuracy Flow Range	Maximum Operating Flow Range
5"	80-3050 gpm (303-11546 L/min)	60-3670 gpm (227-13893 L/min)
6"	117-4500 gpm (443-17035 L/min)	60-3670 gpm (227-13893 L/min)
7"	200-7800 gpm (757-29586 L/min)	60-3670 gpm (227-13893 L/min)

NOTE: FoamPro systems will pump all known Class A and Class B Aqueous Film Forming Foam (AFFF) to capacity. Many brands of Alcohol Resistant-Aqueous Film Forming Foam (AR-AFFF) exhibit higher viscosity characteristics due to chemical composition and polymers. As viscosity increases, diminished flow may affect pump performance. Because of numerous variables, including pump design, foam cell configuration, inlet piping/components, and system layout; please contact FoamPro for application-specific recommendations when foam viscosities of 2000 cps or higher are used.

Standard Components / Options

MODEL	1600	1601	2001	2002	3012	AccuMax Single Point						AccuMax Multi Point				
	1600	1601	2001	2002	3012	3020	3040	3060	3090	3150	3300	3040	3060	3090	3150	3300
Dual Injector Selector (Requires MultiFlo)			0	0	0											
Electric Concentrate Management System			0	0	0	0	0									
Manual Concentrate Management System			0	0												
Remote Start/Stop	0	0	0	0	0	0	0	0	0	0	0					
MultiFlo Interface			0	0	0	0	0	0	0	0	0					
Advanced Feature Controller			0	0	0	0	0	0	0	0	0	S	S	S	S	S
System Schematic and Rating Placards	0	0	0	0	0	0	0	0	0	0	0	0	0	0	0	0
Flow Sensor and Tee	S	S	0	0	0	0	0	0	0	0	0	0	0	0	0	0
Main Waterway Check Valve	0	0	0	0	0	0	0	0	0	0	0	0	0	0	0	0
Low-Level Tank Sensor (Required)	0	0	0	0	0	0	0	0	0	0	0	S	S	S	S	S
Manifold Assembly	0	0	0	0	0	0	0	0	0	0	0	0	0	0	0	0
Concentrate Cell	0	0	0	0												
AccuMax® Line Controller												0	0	0	0	0
Solid State Contractor	0	0	0	0	0	0	0	0	0	0	0	0	0	0	0	0
AccuMax® & 3012 Manual Override					0	0	0	0	0	0	0	0	0	0	0	0
Off-Board Pickup Kit				0	0											
Remote Simulated Flow	0	0														



Dual Injector Selector (Requires MultiFlo)

Allows choice of two different concentrate injection points. Ideal for high/low pressure fire pumps or high-flow (aerial/deluge), low-flow applications.

Available for models:

1600 Series	2000 Series	3012	AccuMax Single-Point	AccuMax Multi-Point
	X	X		



Manual Concentrate Management System

Manually-operated valve allows choice between two different concentrates. Flush mode prevents mixing, and interface with control head provides calibration and storage of performance results of each concentrate.

Available for models:

1600 Series	2000 Series	3012	AccuMax Single-Point	AccuMax Multi-Point
	X			



Electronic Concentrate Management System

Electronically-operated valve allows choice between two different concentrates. Flush mode prevents mixing, and interface with control head provides calibration and storage of performance results of each concentrate.

Available for models:

1600 Series	2000 Series	3012	AccuMax Single-Point	AccuMax Multi-Point
	X	X	3020 & 3040	



Remote Start/Stop

Separately-mounted switch interfaces with digital control head allowing remote activation of the proportioner. Designed for in-cab pump & roll operations.

Available for models:

1600 Series	2000 Series	3012	AccuMax Single-Point	AccuMax Multi-Point
X	X	X	X	

Select Accessories and Options



MultiFlo Interface

Provides calibration and flow totals for up to four different discharges.

Available for models:

1600 Series	2000 Series	3012	AccuMax Single-Point	AccuMax Multi-Point
	X	X	X	



Advanced Feature Controller

Provides programmable choice of activation of proportioning manually by push of ON button or automatically-ON with engagement of fire pump. Ideal for CAFS and SOP's directing foam use.

Available for models:

1600 Series	2000 Series	3012	AccuMax Single-Point	AccuMax Multi-Point
	X	X	X	Standard*

*Auto-on standard in AccuMax multi-Point Systems.



System Schematic and Rating Placards

Attractive placard designed for the operator's panel, listing system ratings or system schematics.

Available for models:

1600 Series	2000 Series	3012	AccuMax Single-Point	AccuMax Multi-Point
X	X	X	X	X



Flow Sensor and Tee

(Required 2000, 3000 & AccuMax™ Series)

Paddlewheel flow sensor reads fire pump discharge flow without restricting performance. Thread sizes (NPT & BSP) available: 1-1/2", 2", 2-1/2", 3" and 4". Also machined for Victaulic coupling. An insertion paddlewheel flow sensor is available for pipe sizes larger than 4". Magnetic flow sensors are available upon request.

Available for models:

1600 Series	2000 Series	3012	AccuMax Single-Point	AccuMax Multi-Point
Standard	X	X	X	X



Main Waterway Check Valve

Prevents backflow to fire pump. Stainless Steel components and construction, rated for 450 psi with NPT thread size or victaulic grooves for 1-1/2", 2", 2-1/2", 3" and 4". Includes tapped injection and drain ports.

Available for models:

1600 Series	2000 Series	3012	AccuMax Single-Point	AccuMax Multi-Point
X	X	X	X	X



Low-Level Tank Sensor (Required)

Provides signal to display, notifying operator of low concentrate condition in foam cell. Available in top/bottom (shown above) or side mount.

Available for models:

1600 Series	2000 Series	3012	AccuMax Single-Point	AccuMax Multi-Point
X	X	X	X	Standard



Manifold Assembly

All stainless steel manifold incorporating flow sensor, check valve, injection and drain ports. Victaulic connections in 1-1/2", 2", 2-1/2", 3" and 4" reduce installation time.

Available for models:

1600 Series	2000 Series	3012	AccuMax Single-Point	AccuMax Multi-Point
X	X	X	X	X

Select Accessories and Options



Concentrate Cell

Polypropylene concentrate tanks with one-way vented cap available in 8, 12, or 20 gallon capacities.

Available for models:

1600 Series	2000 Series	3012	AccuMax Single-Point	AccuMax Multi-Point
X	X	X		



AccuMax® Line Controller

For each controllable discharge, maximum of ten. Sized 1/2", 1", 1-1/4", 1-1/2" and 2". Includes foam controls, driver, cable and LED digital display head. Low-flow option for small handlines.

Available for models:

1600 Series	2000 Series	3012	AccuMax Single-Point	AccuMax Multi-Point
				X



Solid State Contactor

Electronically-controlled DC power switch superior to mechanical solenoids. Longer life and remote start/stop capability.

Available for models:

1600 Series	2000 Series	3012	AccuMax Single-Point	AccuMax Multi-Point
X	X	X	X	X



AccuMax® & 3012 Manual Override

Disengages automatic proportioning, allowing manual proportioning operation.

Available for models:

1600 Series	2000 Series	3012	AccuMax Single-Point	AccuMax Multi-Point
		X	X	X



Off-Board Pickup Kit

Allows automatic on-demand selection of an on-board foam source or an off-board foam source. Provides automatic flushing when switching sources. Available in both a 1" for the 2002 and 1 1/2" for the 3012 system.

Available for models:

1600 Series	2000 Series	3012	AccuMax Single-Point	AccuMax Multi-Point
	X*	X		

*For 2002 model only.



Remote Simulated Flow

Separately mounted switch provides location flexibility for 1600 series simulated flow switch.

Available for models:

1600 Series	2000 Series	3012	AccuMax Single-Point	AccuMax Multi-Point
X				

Specifying a TurboFoam System

Indicate TFC for TurboFoam	TFC _ _ _ - _ _ _ - _ _ _	Example	
Select a Model	1 for 100 2 for 200	3 for 300 4 for 400	TFC-4 _ _ - _ _ _ - _ _ _
Select a Pump Size	16 for 1.6 GPM 26 for 2.6 GPM 50 for 5.0 GPM	62 for 6.2 GPM 65 for 6.5 GPM	TFC-435 - _ _ _ - _ _ _
Select a Power Supply & Unit of Measure	0 for 12 VDC & GPM 1 for 12 VDC & LPM	2 for 24 VDC & GPM 3 for 24 VDC & LPM	TFC-435-0 _ _ - _ _ _
Select a Discharge Pipe Size	10 for 1.0" 15 for 1.5" 20 for 2.0" 25 for 2.5"	30 for 3.0" 35 for 3.5" 40 for 4.0" 50 for 5.0"	TFC-435-025 - _ _ _
Select Options	AB1 - Manual ABF EF0 - Electric Flush Valve FL1 - 1" Foam Tank Check Valve FM1 - Discharge Check Valve Assembly FM2 - Discharge Check Valve Assembly w/Sensor Mount FS2 - Tank Float Switch RS0 - Remote ON/OFF Switch AL1, PT1, SC1, SS1, ST1 - Flow Sensor Mount		TFC-435-025-FM2RS0

TurboFoam Standard Components / Options

MODEL	TFC116	TFC126	TFC150	TFC162	TFC165	TFC216	TFC226	TFC250	TFC262	TFC265	TFC316	TFC326	TFC350	TFC362	TFC365	TFC416	TFC426	TFC450	TFC462	TFC465	
Manual ABF Selector						0	0	0	0	0											
Electric ABF Selector																S	S	S	S	S	
Flow Sensor with Mount	S	S	S	S	S	S	S	S	S	S	S	S	S	S	S	S	S	S	S	S	S
Foam Tank Check Valve 3/4"	S	S				S	S														
Foam Tank Check Valve 1"	0	0	S	S	S	0	0	S	S	S	S	S	S	S	S	S	S	S	S	S	S
Foam Pump Input Strainer 3/4"	S	S				S	S														
Foam Pump Input Strainer 1"	0	0	S	S	S	0	0	S	S	S	S	S	S	S	S	S	S	S	S	S	S
Check Valve Injector 1/2"	S	S	S	S	S	S	S	S	S	S	S	S	S	S	S	S	S	S	S	S	S
Flush Line Strainer 1/2" 1	0	0	0	0	0	0	0	0	0	0	S	S	S	S	S	S	S	S	S	S	S
Flush Line Check Valve 1/2" 1	0	0	0	0	0	0	0	0	0	0	S	S	S	S	S	S	S	S	S	S	S
Electric Flush Valve	0	0	0	0	0	0	0	0	0	0	S	S	S	S	S						
Summing Box						0	0	0	0	0	0	0	0	0	0	0	0	0	0	0	0
Discharge Check Valve Assy	0	0	0	0	0	0	0	0	0	0	0	0	0	0	0	0	0	0	0	0	0
Discharge Check Valve Assy with Flow Sensor Mount	0	0	0	0	0	0	0	0	0	0	0	0	0	0	0	0	0	0	0	0	0
Remote ON/OFF Switch	0	0	0	0	0	0	0	0	0	0	0	0	0	0	0	0	0	0	0	0	0
Tank Float Switch	0	0	0	0	0	0	0	0	0	0	0	0	0	0	0	0	0	0	0	0	0
BSP Fittings	0	0	0	0	0	0	0	0	0	0	0	0	0	0	0	0	0	0	0	0	0
B Foam Program Active 2	0	0	0	0	0	0	0	0	0	0	0	0	0	0	0	0	0	0	0	0	0

Notes: 1 The flush line strainer and check valve are standard when the Manual ABF Selector or B Foam Program options are included.
 2 The standard control module is factory set with the A foam program active.

Select Accessories and Options



Electric ABF Selector

The electric ABF selector is standard on the TFC400 models. It allows the operator to select Class A foam, Class B foam, or flushing operations from the push buttons on the control module. The selector is installed between the foam tanks and the foam pump assembly intake and has an input for flush water. The electric model is made up of three electric valves mounted on a manifold that controls the flow of foam concentrate or flush water into the system. On each of the valve covers there is a dial indicator to show the valve position and an allen head screw that allows for manual adjustment of the valve position.

Remote ON/OFF Switch & Indicator

The remote switch and indicator mirrors the control module ON/OFF button and LED on the control module.

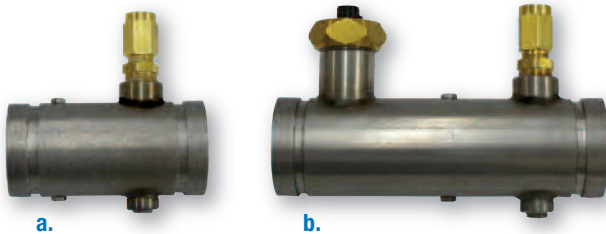

Discharge Check Valve Assembly

- a. Includes a water way check valve, check valve injector port, and a drain.
- b. Includes a flow sensor mount, water way check valve, check valve injector port, and a drain.

Information Placards



These helpful informational reference placards provide capacity specifications, plumbing schematics, and operator instructions.

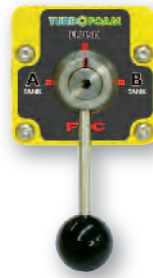

Manual ABF Selector

The manual ABF selector is an option with the TFC200 models. It allows the operator to select Class A foam, Class B foam, or Flushing operations by rotating the ABF selector handle. The selector is connected between the foam tanks and the foam pump assembly intake and has an input for flush water. Two check valves are included with this option that must be installed between the foam tanks and the selector.



Electric Flush Valve

The electric valve is standard on the TFC300 models and an option with the TFC100/200 single tank systems. It is used to provide flush or prime capabilities for the concentrate pump.



TankVision or Tank Float Switch

A TankVision sensor or tank float switch is required to be installed in the foam tank to provide the tank empty signal to the control module. The TankVision is connected to the control module on the datalink and provides tank volume data. If a tank float switch is installed, it is connected to the tank empty inputs on the control module.

Plumbing Components



Strainer

Check Valve

Paddlewheel Discharge Flow Sensor

Specifying an AutoFoam System

Kit Numbers	Description
FSB015-XXX	0.5 to 15 GPM foam concentrate flow rate
FSB030-XXX	0.5 to 30 GPM foam concentrate flow rate
FSB060-XXX	1.5 to 60 GPM foam concentrate flow rate
FSB120-XXX	2.0 to 120 GPM foam concentrate flow rate
FSB240-XXX	10.0 to 240 GPM foam concentrate flow rate

Standard Kit includes: control module, proportioning valve assembly, eductor, discharge flow sensor with mount, and cables.

For a kit with multiple discharges: XXX = Number of Discharges (002 to 008). *The mount type and pipe diameter must be specified for each discharge.*

For a kit with a single discharge: XXX = Pipe Diameter. *Available diameter varies with mount type.*

Select System Options

Flow Rates Displayed in LPM.

Discharge flow sensor mount pipe diameters (in inches) 01.0, 01.5, 02.0, 02.5, 03.0, 03.5, 04.0, 05.0, 06.0, 08.0

Discharge Flow Sensor Mounts

Kit Numbers	Description
-SC1	Saddle Clamp
-ST1	Weldment, Steel
-SS1	Weldment, Stainless
-AL1	Weldment, Aluminum
-PT1	Pipe Tee

To order a sensor mount with a flow conditioner, change the 1 to a 2. Example: -SC2 Saddle Clamp with flow conditioner.

Custom Spacer: Available, contact factory.

Select Flow Sensor Mounting Options

A. Saddle Clamps are the standard mountings for 2" through 6" pipe sizes.

B. Weldment fittings are available in aluminum, steel, and stainless steel.

C. Pipe Tee fittings are NPT threaded, ranging from 1" through 4" for applications where standard pipe fittings are the easiest solution



A.



B.



C.

Specifying a Manual Foam System

200 System Kit Numbers	300 System Kit Numbers	Description
MFA200	MFA315	Manual Foam System, Class A
MFA201	MFA342	Manual Foam System, Class B
MFA220	MFA320	Manual Foam System, Class A & B

Specifying a TurboStream® System

Model Number	Capacity GPM (L/min)	Pressure PSI (bar)	Drive Source	Fuel Type
S108-4008	8 (30)	1400 (96)	PowerPro™ 13 HP (9.7 kw)	Gas
S108-4008H	8 (30)	1400 (96)	Honda GX390 13 HP	Gas

System components include: PowerPro or Honda gas engine with electric and recoil start or hydraulic motor, triplex plunger pump, foam proportioner, pressure and thermal relief valves, and spray gun.

Specifying a Power-Fill™ Foam Refill System

Part Number	Description	Voltage
3435-0134	12 VDC Powered, On-board mounting	12
3435-0135	24 VDC Powered, On-board mounting	24
3435-0118	120 AC Powered, Complete portable	120
3435-0187	240 AC Powered, Complete portable	240
3435-0120	Panel Kit, Portable plumbing kit only	—

DC powered system components include: Concentrate pump and motor, panel-mount operator control unit, check valves, side-mount low-level sensor, panel-mount flush valve, placard and camlok intake connection, stainless steel pick-up wand with 6 foot suction hose, camlok fittings and cap.

AC powered system components include: Portable pump and motor with carrying handle, 25 foot electrical cord with GFI protection and control switch, check-valve, side-mount low-level sensor, panel-mount placard and camlok intake connection, stainless steel pick wand with 6 foot suction hose, camlok fittings, and cap.

Panel Kit includes: Check-valve, side-mount low-level sensor, panel-mount placard and camlok intake connection, and cap.



Learn more online or request our FRC full line catalogs of the brightest, high intensity LED lighting, instruments, controls, displays, accessories AND VIDEO SYSTEMS.

FOAMPRO®

A Safe Fleet Brand

26 Southern Blvd. Nesconset, NY 11767 • Tel : 631.724.8888 • Fax : 631.360.9727

1.800.645.0074

foampro.com • fireresearch.com



FIRE
APPARATUS
MANUFACTURERS'
ASSOCIATION

Active Member and Supporter



facebook.com
/ fire.research.corp

